

SINGLE LINE
CENTRALIZED
LUBRICATION
SYSTEM

VOLUMETRIC SYSTEM

LUBRICATION SYSTEMS

ILC



VOLUMETRIC SYSTEM

INDEX









INTRODUCTION	4 - 5
MANUAL PUMPS PRD-13	6 - 7
MANUAL PUMPS PRDG-13	8
PRA PNEUMATIC PUMPS	9
PRA 13 FOR OIL	10
PRA-13-G FOR SOFT-GREASE	11
PRA-15 FOR OIL	12
PRA-20/25/30 FOR OIL	13
PRA-30/35/LAM FOR OIL	14
PRA-20/25/30 FOR SOFT GREASE	15
PRA-30/35/LAM FOR SOFT GREASE	16
PRA WITHOUT RESERVOIR	17
MPT ELECTRIC PUMPS	18 - 20
MPT-200 FOR OIL	21 - 22
MPT-500 FOR OIL	23 - 24
MPT-200 FOR SOFT GREASE	25 - 26
MPT-500 FOR SOFT GREASE	27 - 28
MPT WITHOUT RESERVOIR	29
CME ELECTRIC PUMPS	30 - 34
CME FOR OIL	35
CME FOR SOFT GREASE	36
CME WITH 24 V DC MOTOR	37
VOLUMETRIC METERING VALVES	38 - 40
VALVES FOR MANIFOLD	41 - 43
MANIFOLD	44 - 47
VALVES FOR POINT	47

VALVES FOR MANIFOLD	48 - 49
MANIFOLD 1/8"	50 - 51
VALVES FOR POINT	52 - 54
TERMINALS REVOLVING	55 - 56
METERING VALVE ILCOMATIC-3	57 - 64
AIR+OIL MIX VALVE	65 - 69
SP-43 PRESSURE SWITCHES	70
PFL END OF LINE PRESSURE SWITCH	71
OIL AND GREASE LINE STRAINER	72
ELECTRONIC CARD	73
LUBRICANTS	74

CENTRALIZED LUBRICATION

AN ECONOMICAL WAY TO MAINTAIN MACHINERY AT OPTIMUM PERFORMANCE.

MOVING LUBRICANT LUBRICATION POINTS TO ONE LOCATION PROVIDES THE FOLLOWING BENEFITS:

-  Minimizes preventive maintenance time by lubricating from one location.
-  Provides renewable lubrication without machinery shut-down for continuous production.
-  Enhances personnel safety by lubricating from a centralized location away from moving machinery parts.
-  Extends the life expectancy of bearings and moving parts operating in harsh environments by more frequent lubrication.
-  Does not add another system to maintain. Once installed, centralized lubrication blocks require no periodic maintenance.
-  Maximizes machinery production time by minimizing lubrication-related failures.
-  Maintenance personnel appreciate the ease with which they can adhere to preventive maintenance schedules.
-  Centralized lubrication is the most simplified and economical installation possible.
-  The possibility of overlooking a remote or difficult-to-reach lubrication point is eliminated.

SINGLE LINE LUBRICATION SYSTEMS ARE A POSITIVE HYDRAULIC METHOD OF DELIVERING LUBRICANT, EITHER OIL OR SOFT-GREASE, UNDER PRESSURE TO A GROUP OF POINTS FROM ONE CENTRALLY LOCATED PUMPING UNIT. THE PUMP SUPPLIES LUBRICANT TO ONE OR MORE METERING VALVES. THE VALVES ARE PRECISION MEASURING DEVICES AND DELIVER AN ACCURATE METERED VOLUME OF LUBRICANT TO EACH POINT. A TYPICAL SYSTEM IS SHOWN IN **FIGURE 1**.

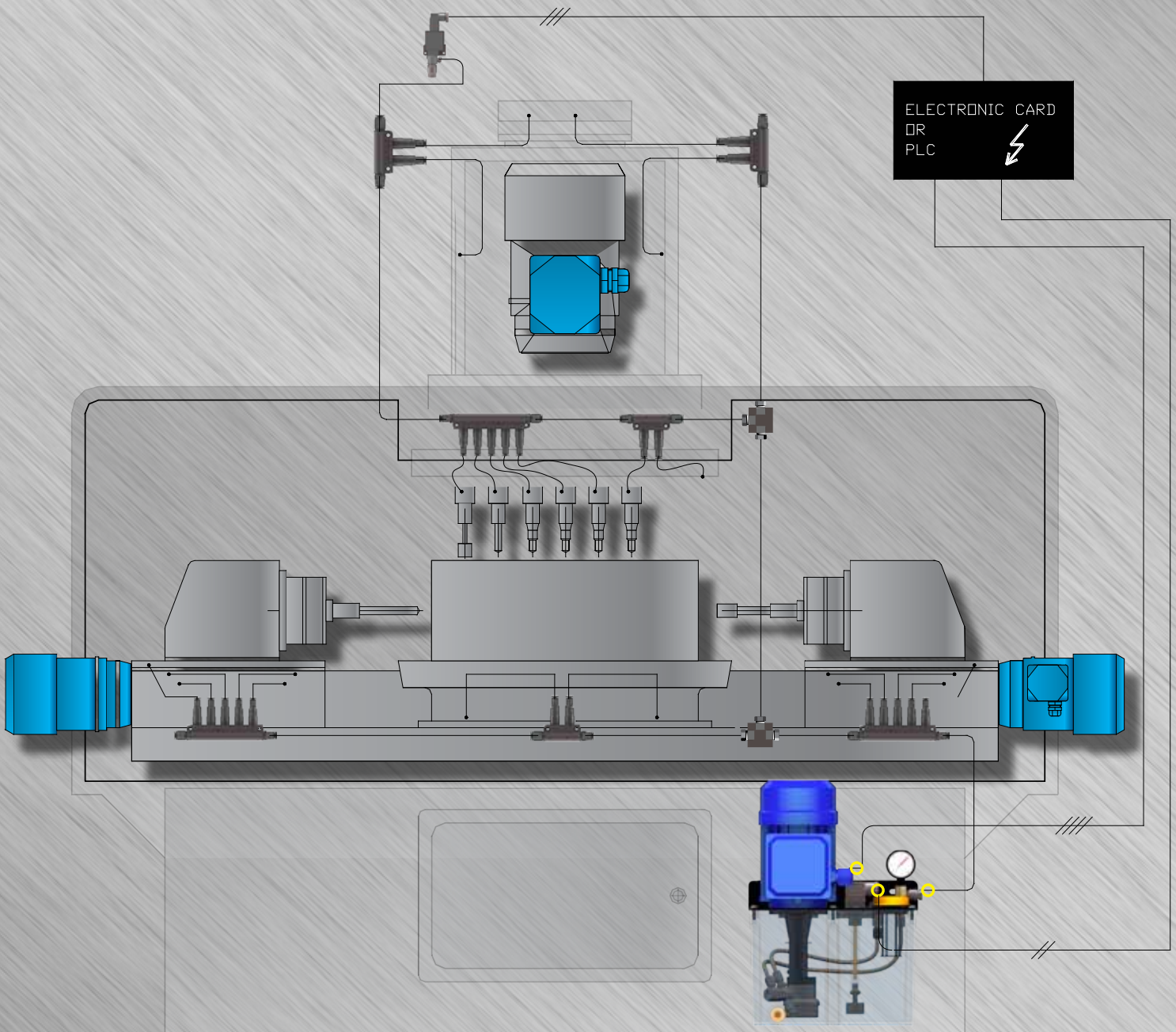

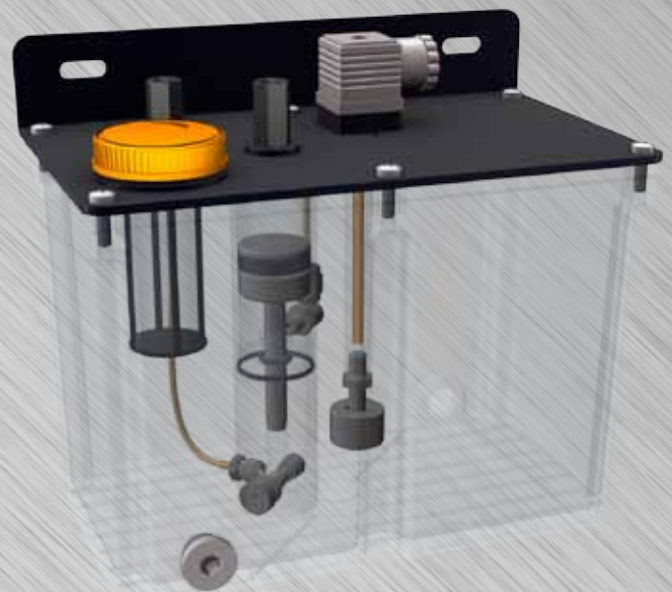

The manual pumps prd - 13 are supplied for centralized lubrication system with oil where volumetric metering units are used. The pumps assembly are located on the bottom of the reservoir and the vertical lever comes back by means of a spring. Before to use again the vertical lever has to be awaited minimum 15/20 seconds to have a correct working of the system. The pumps are provided with a set of valves which carries out priming, releasing and relieving. They are provided with suction strainer and strainer filler cup.

Technical Features

DISCHARGE/CYCLE	13 CC
WORKING PRESSURE	35 bar MAX
RELEASE VALVE	0.7 bar
PLASTIC RESERVOIR	1 L
SUCTION STRAINER	250 MICRON
DISCHARGE PORT	M12X1 TUBE 6 MM
TEMPERATURE RANGE	FROM - 10°C TO + 80°C
LUBRICANTS	OIL 50 - 1000 cSt 40°C
MOUNTING	VERTICALLY



Codes For Order

CODE	TYPE	RESERVOIR CAPACITY	DISCHARGE PORT
00.123.0	PRD - 13 NY-SX	1 L	LEFT
00.123.1	PRD - 13 NY-DX	1 L	RIGHT

Overall Dimension

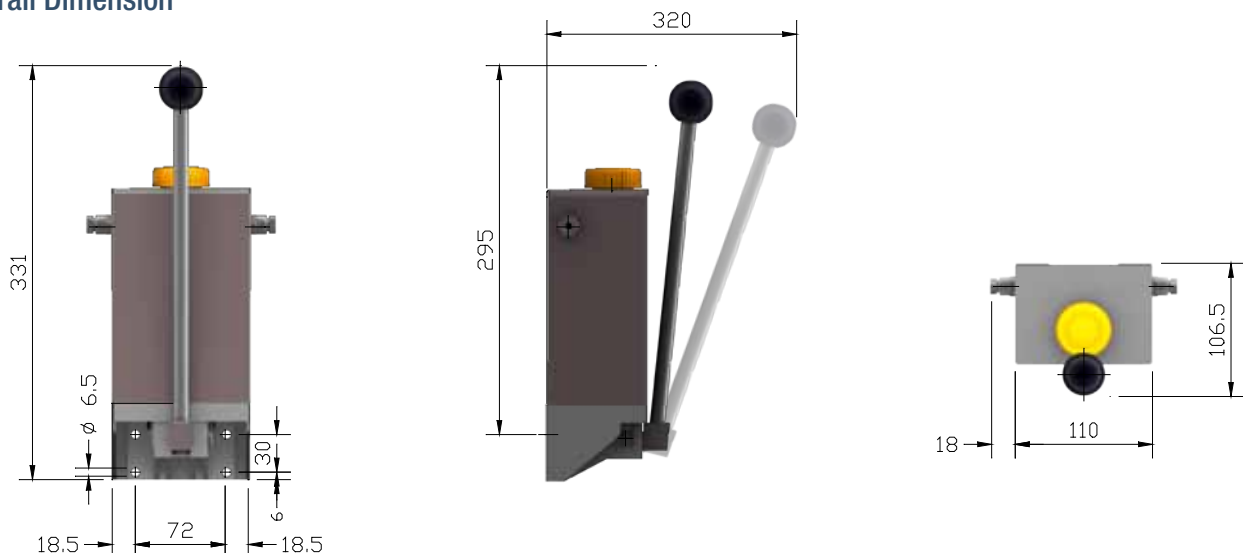

PRDG-13 SOFT-GREASE MANUAL PUMP

The manual pumps prdg - 13 are supplied for centralized lubrication system with soft-grease where volumetric metering units are used. The pumps assembly are located on the bottom of the reservoir and the vertical lever comes back by means of a spring. Before to use again the vertical lever has to be awaited minimum 15/20 seconds to have a correct working of the system. The pumps are provided with a set of valves which carries out priming, releasing and relieving. They are provided with suction strainer and strainer filler cup.



Technical Features

DISCHARGE/CYCLE	13 CC
WORKING PRESSURE	35 bar MAX
RELEASE VALVE	0.7 bar
PLASTIC RESERVOIR	1 L
SUCTION STRAINER	250 MICRON
DISCHARGE PORT	M12X1 TUBE 6 MM
TEMPERATURE RANGE	FROM - 10°C TO + 80°C
LUBRICANTS	SOFT GREASE NLGI 000-00
MOUNTING	VERTICALLY

Codes For Order

CODE	TYPE	RESERVOIR CAPACITY	DISCHARGE PORT
00.122.1	PRDG - 13 NY-SX	1 L	LEFT
00.122.0	PRDG - 13 NY-DX	1 L	RIGHT

Overall Dimension

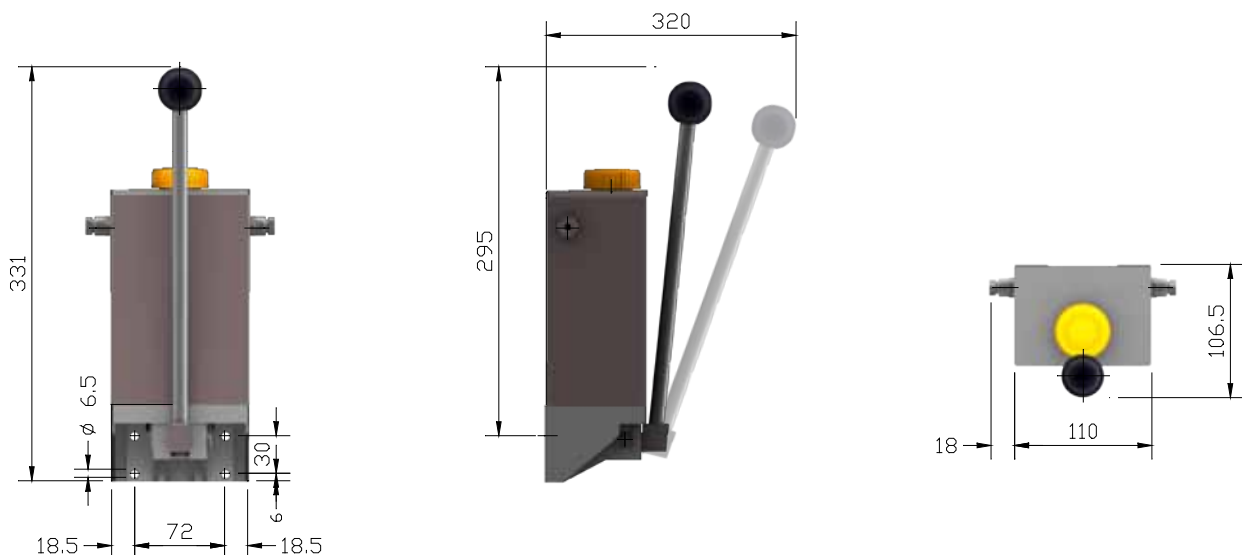

PRA PNEUMATIC PUMPS

The pneumatic pump pra is supplied for centralized lubrication system with oil or soft grease where volumetric metering valves are used. The pump assembly is located over the reservoir and the air has to be send via a 3-ways solenoid valve (line - cylinder - release). The piston comes back by means of a spring. The pause time has not to be less than 15 seconds for a correct use of the pump.

The pump is provided with a suction valve, a check valve, a release valve, a suction strainer, a strainer filler cup and a low level switch. It is possible to supply on request a pressure gauge.

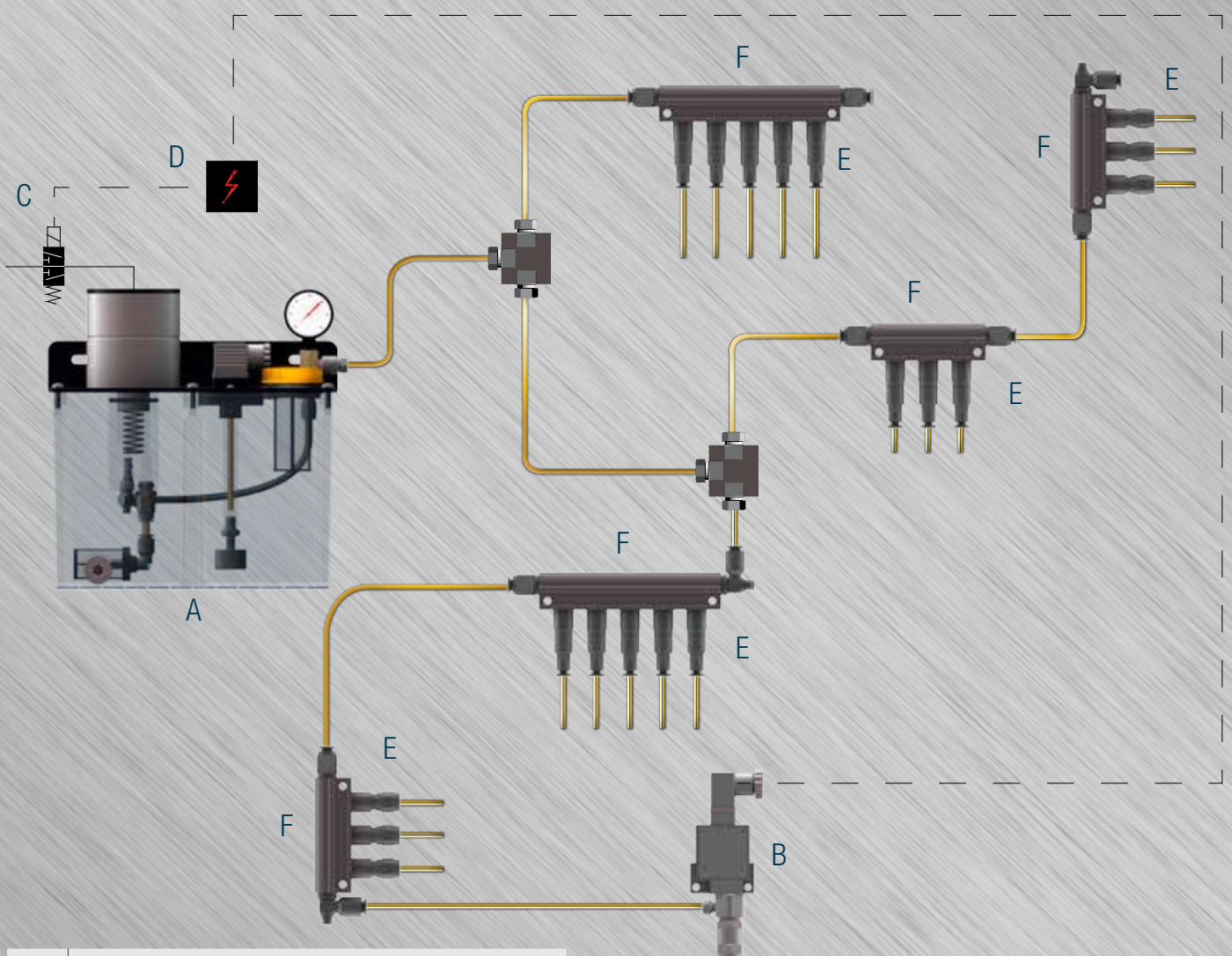

A	PRA PNEUMATIC PUMP
B	PRESSURE SWITCH
C	SOLENOID VALVE
D	ELECTRONIC CARD OR PLC
E	VOLUMETRIC METERING UNITS
F	MANIFOLDS

PRA-13 OIL PNEUMATIC PUMP

Technical Features

DISCHARGE/CYCLE	13 CC
WORKING PRESSURE	30 bar (425 PSI) MAX
RATIO	4.5 ÷ 1
AIR OPERATING PRESSURE	DA 4 bar A 7 bar
	FROM 60 PSI TO 100 PSI
RELEASE VALVE	0.7 bar (10 PSI)
CYCLES NUMBER/MINUTE	MAX 4
PLASTIC RESERVOIR	1 L
SUCTION STRAINER	250 MICRON
DISCHARGE PORT	M12X1 TUBE 6 MM
TEMPERATURE RANGE	FROM - 10°C TO + 80°C
LUBRICANTS	OIL 50-1000 cSt 40°C
LOW LEVEL SWITCH	1.5 A 250 V AC 150 V DC
AIR INLET	1 / 4" G



Codes For Order

CODE	TYPE	OUTLET POSITION	LOW LEVEL SWITCH
00.221.0	PRA-13 NY DX	RIGHT	NO
00.221.1	PRA-13 NY-LV DX	RIGHT	YES
00.221.2	PRA-13 NY SX	LEFT	NO
00.221.3	PRA-13 NY-LV SX	LEFT	YES

Overall Dimension

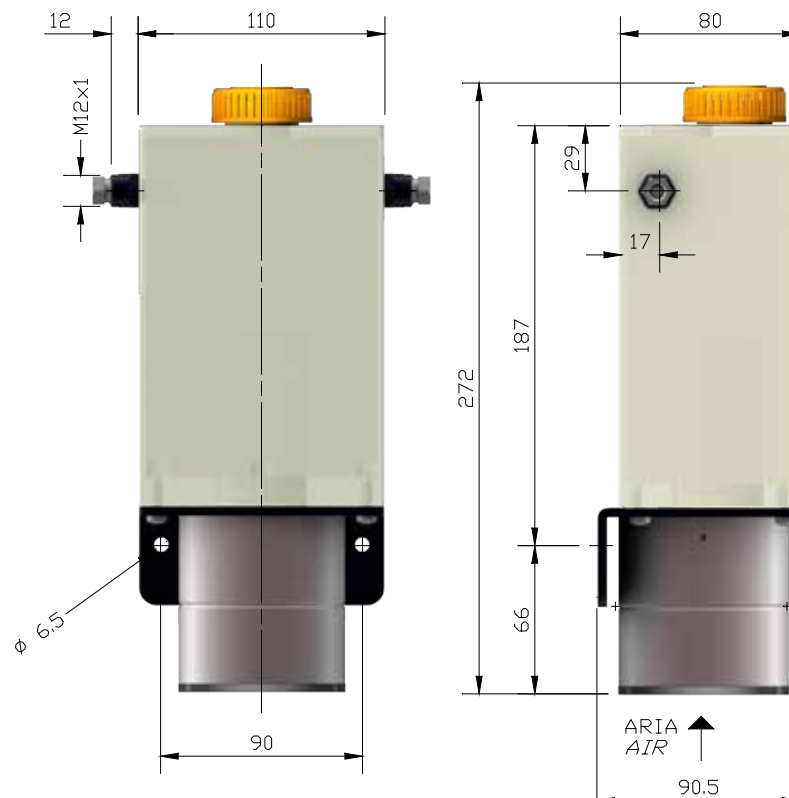

PRA-13-G SOFT-GREASE PNEUMATIC PUMP



Technical Features

DISCHARGE/CYCLE	13 CC
WORKING PRESSURE	30 bar (425 PSI) MAX
RATIO	4.5 ÷ 1
AIR OPERATING PRESSURE	FROM 4 bar TO 7 bar
	FROM 60 PSI TO 100 PSI
RELEASE VALVE	0.7 bar (10 PSI)
CYCLES NUMBER/MINUTE	MAX 4
PLASTIC RESERVOIR	1 L
SUCTION STRAINER	250 MICRON
DISCHARGE PORT	M12X1 TUBE 6 MM
TEMPERATURE RANGE	FROM - 10°C TO + 80°C
LUBRICANTS	SOFT GREASE NLGI 000-00
AIR INLET	1 / 4" G



Codes For Order

CODE	TYPE	OUTLET POSITION	LOW LEVEL SWITCH
00.225.5	PRA-13-G NY DX	RIGHT	NO
00.225.4	PRA-13-G NY SX	LEFT	NO

Overall Dimension

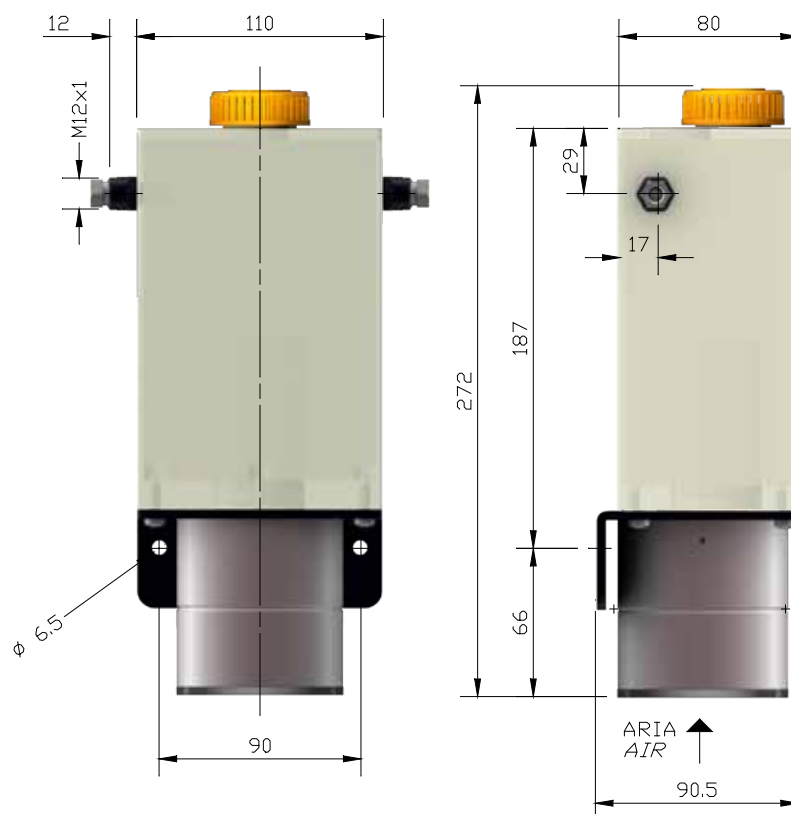

PRA-15 OIL PNEUMATIC PUMP

Technical Features

DISCHARGE/CYCLE	2.7 CC
WORKING PRESSURE	56 bar (795 PSI) MAX
RATIO	8 ÷ 1
AIR OPERATING PRESSURE	FROM 4 bar TO 7 bar FROM 60 PSI TO 100 PSI
RELEASE VALVE	0.7 bar (10 PSI)
CYCLES NUMBER/MINUTE	MAX 6
PLASTIC RESERVOIR	2 L – 3.6 L
SUCTION STRAINER	250 MICRON
DISCHARGE PORT	1/8" - TUBE 6 MM
TEMPERATURE RANGE	FROM - 10°C TO + 80°C
LUBRICANTS	OIL 50-1000 cSt 40°C
LOW LEVEL SWITCH	1.5 A 250 V AC – 150 V DC
AIR INLET	1 / 8" G

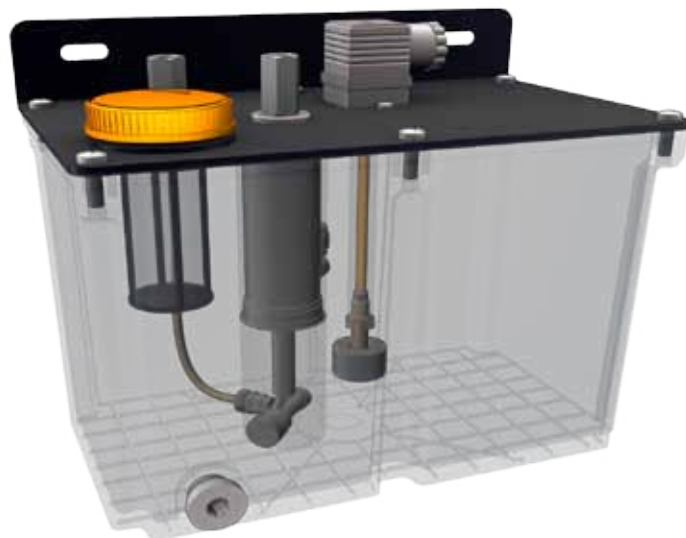

Codes For Order

CODE	TYPE	OUTLET POSITION	RETURN FILTER
00.224.3	PRA-15/2	2 L	NO
00.224.6	PRA-15/3.6	3.6 L	NO

Overall Dimension

PUMP	A	B	C	D	E	F
PRA-15/2	160	186	201	122.5	123	148
PRA-15/3.6	156	182	197	172.5	135	230

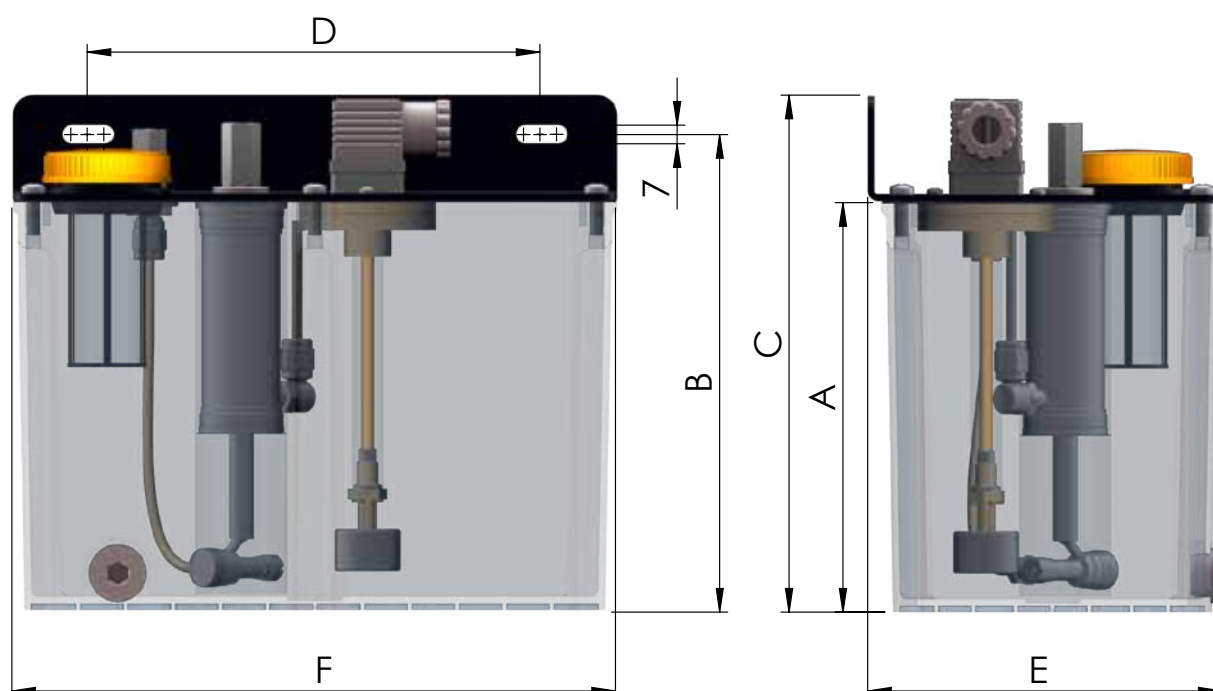

PRA-20/25/30 OIL PNEUMATIC PUMP



Technical Features

DISCHARGE/CYCLE	13 CC
WORKING PRESSURE	30 bar (425 PSI) MAX
RATIO	4.5 ÷ 1
AIR OPERATING PRESSURE	FROM 4 bar TO 7 bar FROM 60 PSI TO 100 PSI
RELEASE VALVE	0.7 bar (10 PSI)
CYCLES NUMBER/MINUTE	MAX 4
RESERVOIR	2 L - 3.6 L - 6 L - 5 L
SUCTION STRAINER	250 MICRON
PRESSURE GAUGE	0-60 bar / 0-850 PSI
DISCHARGE PORT	M12x1 - TUBE 6 MM
TEMPERATURE RANGE	FROM - 10°C TO + 80°C
LUBRICANTS	OIL 50-1000 cSt 40°C
LOW LEVEL SWITCH	1.5 A 250 V AC - 150 V DC
AIR INLET	1 / 4" G



Codes For Order

CODE	TYPE	RESERVOIR CAPACITY
00.223.1	PRA-20 NY	2 L NYLON
00.226.1	PRA-25 NY	3.6 L NYLON
00.227.0	PRA-30 NY	6 L NYLON
00.226.4	PRA-25 LA	5 L METALLIC

Overall Dimension

PUMP	A	B	C	D	E	F
PRA-20 NY	160	186	242.5	125	123	148
PRA-25 NY	155	181	237.5	172.5	135	230
PRA-30 NY	250	276	332.5	172.5	135	230
PRA-25 LA	156	182	238.5	172.5	153	236

NYLON RESERVOIR

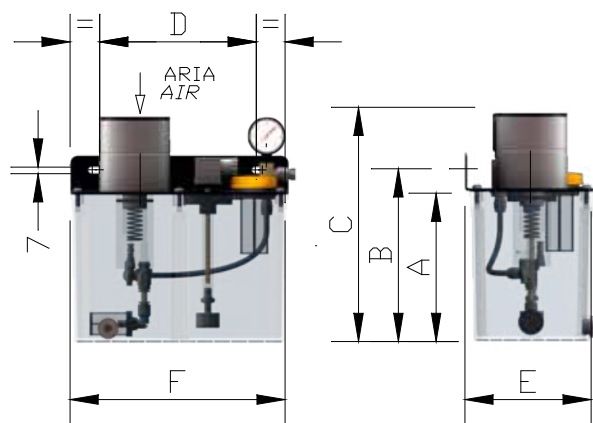

METALLIC RESERVOIR

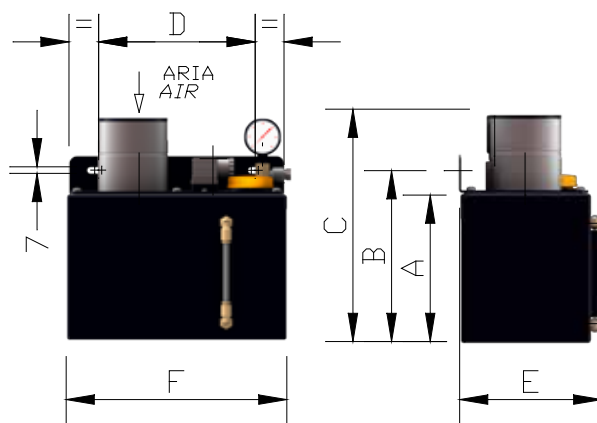

PRA-30/35/LAM OIL PNEUMATIC PUMP

Technical Features

DISCHARGE/CYCLE	13 CC
WORKING PRESSURE	30 bar (425 PSI) MAX
RATIO	4.5 ÷ 1
AIR OPERATING PRESSURE	FROM 4 bar A 7 bar
	FROM 60 PSI A 100 PSI
RELEASE VALVE	0.7 bar (10 PSI)
CYCLES NUMBER/MINUTE	MAX 4
METALLIC RESERVOIR	8 L – 12 L
SUCTION STRAINER	250 MICRON
PRESSURE GAUGE	0-60 bar / 0-850 PSI
DISCHARGE PORT	M12x1 - TUBE 6 MM
TEMPERATURE RANGE	FROM - 10°C TO + 80°C
LUBRICANTS	OIL 50-1000 cSt 40°C
LOW LEVEL SWITCH	1.5 A 250 V AC – 150 V DC
AIR INLET	1 / 4" G



Codes For Order

CODE	TYPE	RESERVOIR CAPACITY
00.226.3	PRA-30 LAM	8 L
00.227.5	PRA-35 LAM	12 L

Overall Dimension

PUMP	A	B	C
PRA-30 LA	305	330	165
PRA-35 LA	330	355	198

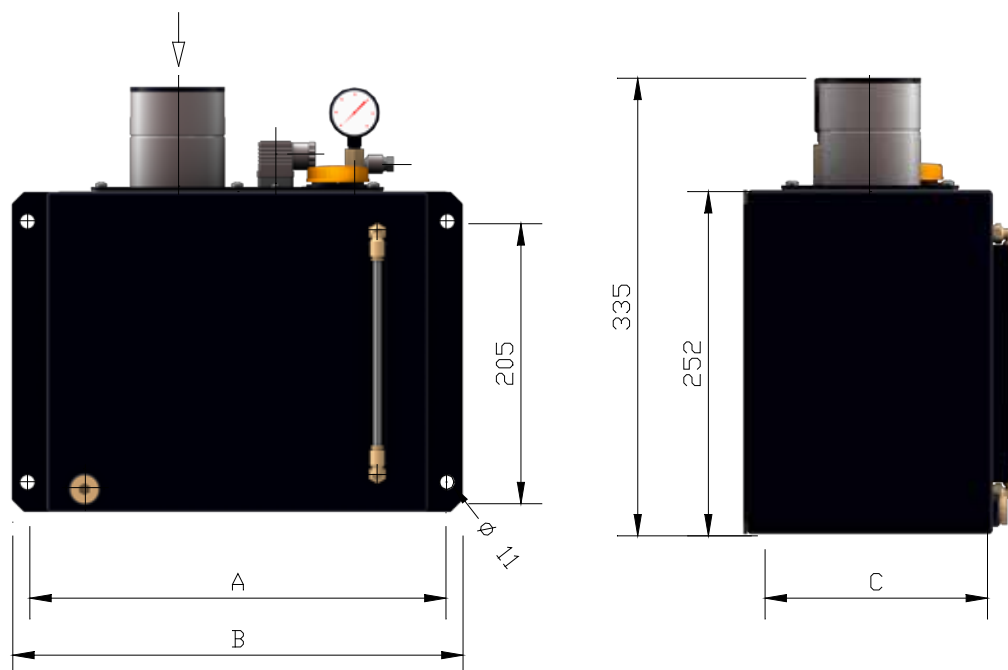

PRA-20/25/30/G SOFT GREASE PNEUMATIC PUMP

Technical Features

DISCHARGE/CYCLE	13 CC
WORKING PRESSURE	30 bar (425 PSI) MAX
RATIO	4.5 ÷ 1
AIR OPERATING PRESSURE	FROM 4 bar TO 7 bar
	FROM 60 PSI TO 100 PSI
RELEASE VALVE	0.7 bar (10 PSI)
CYCLES NUMBER/MINUTE	MAX 4
RESERVOIR	2 L – 3.6 L – 6 L – 5 L
SUCTION STRAINER	250 MICRON
PRESSURE GAUGE	0-60 bar / 0-850 PSI
DISCHARGE PORT	M12x1 - TUBE 6 MM
TEMPERATURE RANGE	FROM - 10°C TO + 80°C
LUBRICANTS	SOFT GREASE NLGI 000 - 00
LOW LEVEL SWITCH	FROM 10 TO 40 V DC
AIR INLET	1 / 4" G



Codes For Order

CODE	TYPE	RESERVOIR CAPACITY
00.228.0	PRA-20-G NY	2 L NYLON
00.228.1	PRA-25-G NY	3.6 L NYLON
00.228.2	PRA-30-G NY	6 L NYLON
00.226.0	PRA-25-G LA	5 L METALLIC

Overall Dimension

PUMP	A	B	C	D	E	F
PRA-20-G NY	160	186	242.5	125	123	148
PRA-25-G NY	155	181	237.5	172.5	135	230
PRA-30-G NY	250	276	332.5	172.5	135	230
PRA-25-G LA	156	182	238.5	172.5	153	236

NYLON RESERVOIR

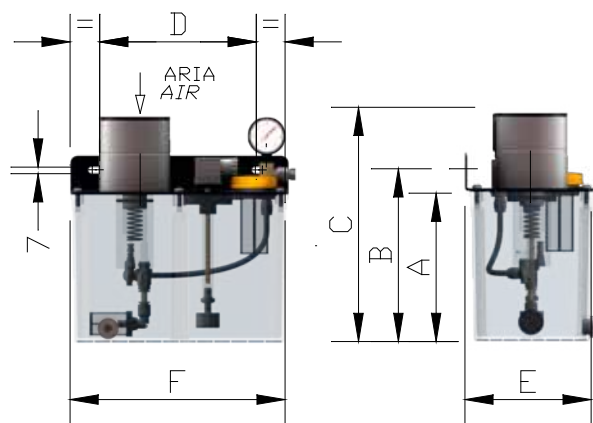

METALLIC RESERVOIR

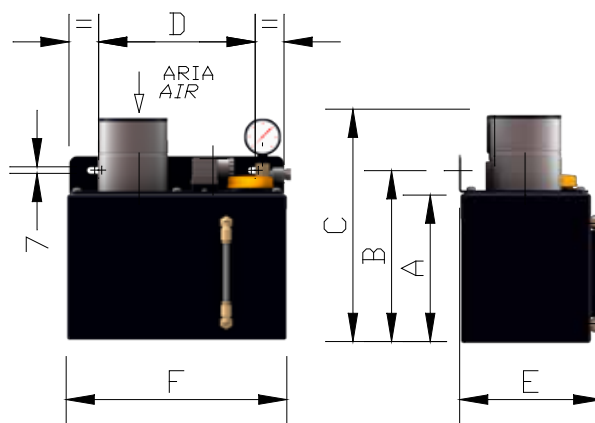

PRA-30/35/G/LAM SOFT GREASE PNEUMATIC PUMP

Technical Features

DISCHARGE/CYCLE	13 CC
WORKING PRESSURE	30 bar (425 PSI) MAX
RATIO	4.5 ÷ 1
AIR OPERATING PRESSURE	FROM 4 bar TO 7 bar
	FROM 60 PSI TO 100 PSI
RELEASE VALVE	0.7 bar (10 PSI)
CYCLES NUMBER/MINUTE	MAX 4
METALLIC RESERVOIR	8 L – 12 L
SUCTION STRAINER	250 MICRON
PRESSURE GAUGE	0-60 bar / 0-850 PSI
DISCHARGE PORT	M12x1 - TUBE 6 MM
TEMPERATURE RANGE	FROM - 10°C TO + 80°C
LUBRICANTS	SOFT GREASE NLGI 000 - 00
LOW LEVEL SWITCH	10 A TO 40 V DC
AIR INLET	1 / 4" G



Codes For Order

CODE	TYPE	RESERVOIR CAPACITY
00.226.7	PRA-30-G LAM	8 L
00.226.8	PRA-35-G LAM	12 L

Overall Dimension

PUMP	A	B	C
PRA-30-G LA	305	330	165
PRA-35-G LA	330	355	198

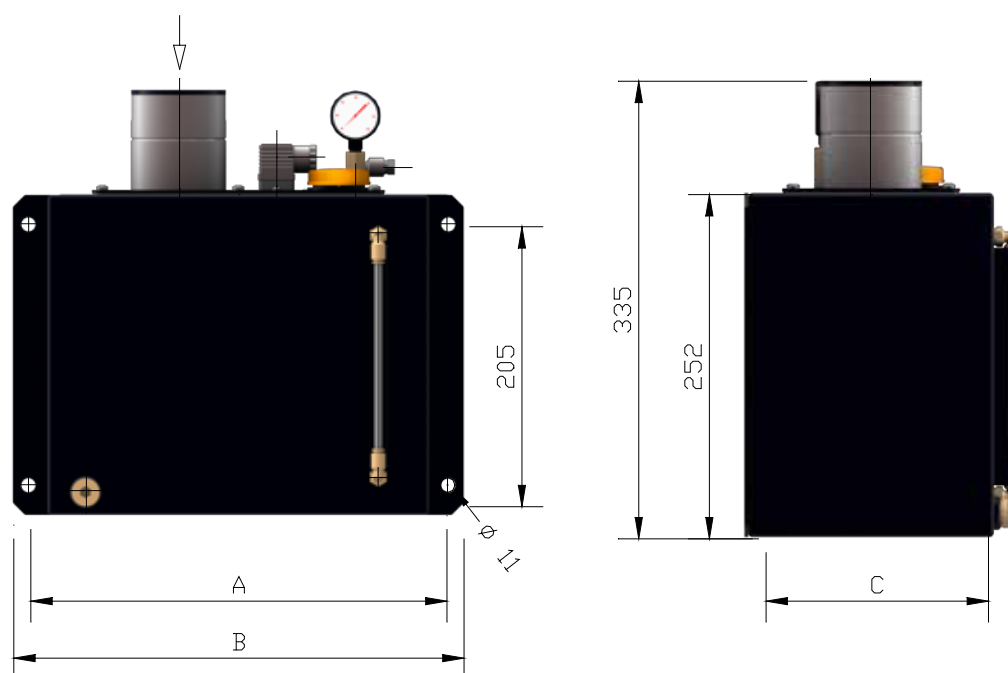

PRA PNEUMATIC PUMP WITHOUT RESERVOIR

Technical Features

DISCHARGE/CYCLE	13 CC
WORKING PRESSURE	30 bar (425 PSI) MAX
RATIO	4.5 ÷ 1
AIR OPERATING PRESSURE	FROM 4 bar TO 7 bar
	FROM 60 PSI TO 100 PSI
RELEASE VALVE	0.7 bar (10 PSI)
CYCLES NUMBER/MINUTE	MAX 4
DISCHARGE PORT	M10x1 - TUBE 6 MM
TEMPERATURE RANGE	FROM - 10°C TO + 80°C
LUBRICANTS	SOFT GREASE NLGI 000 – 00
	OIL 50-1000 cSt 40 °C
AIR INLET	1/4" G



CODE	TYPE
00.220.0	PRA-SS

Overall Dimension

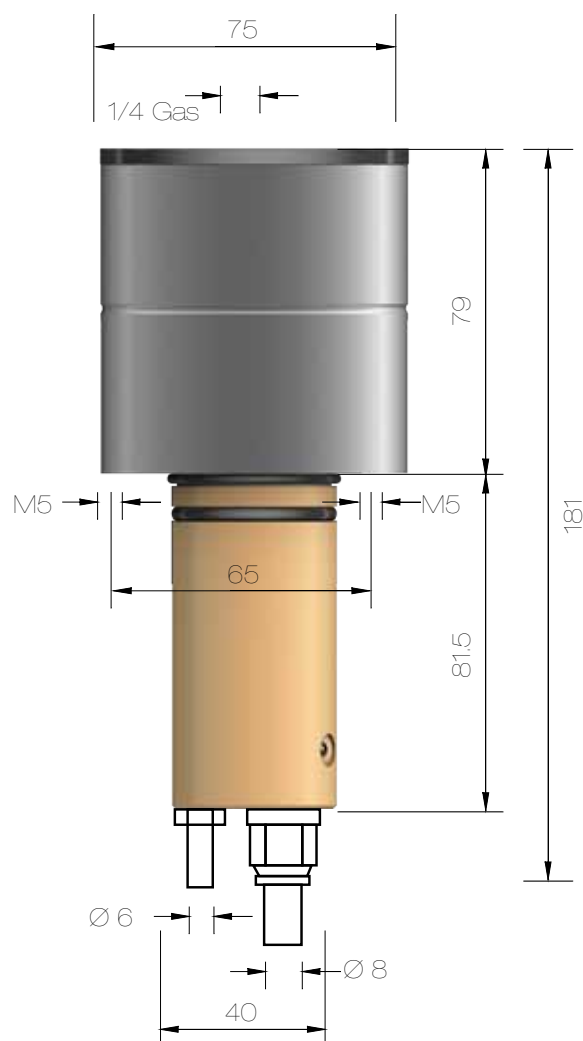

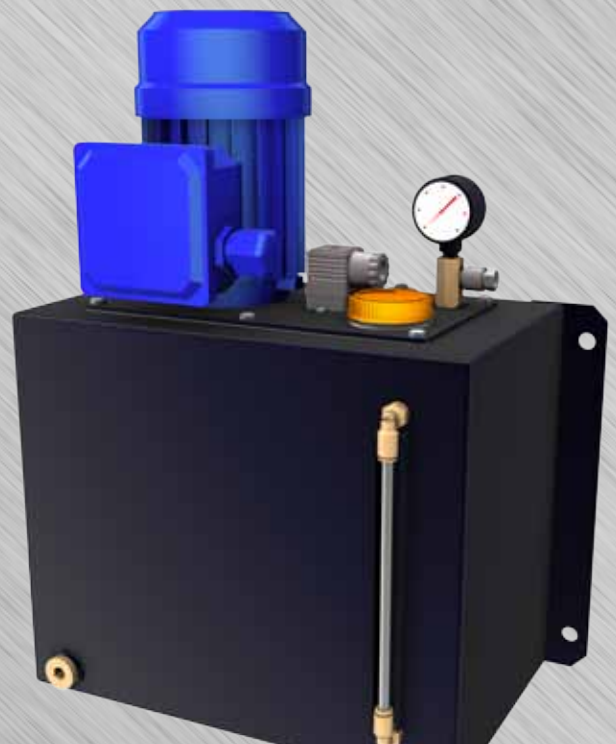
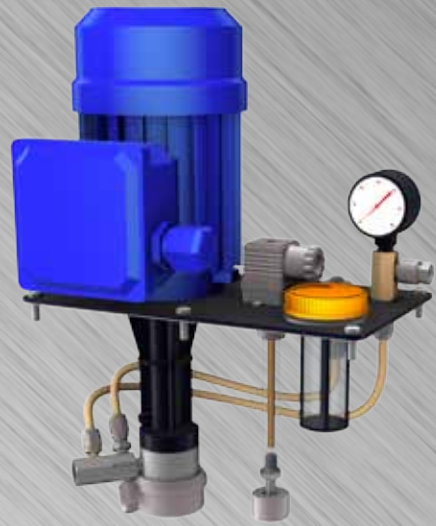
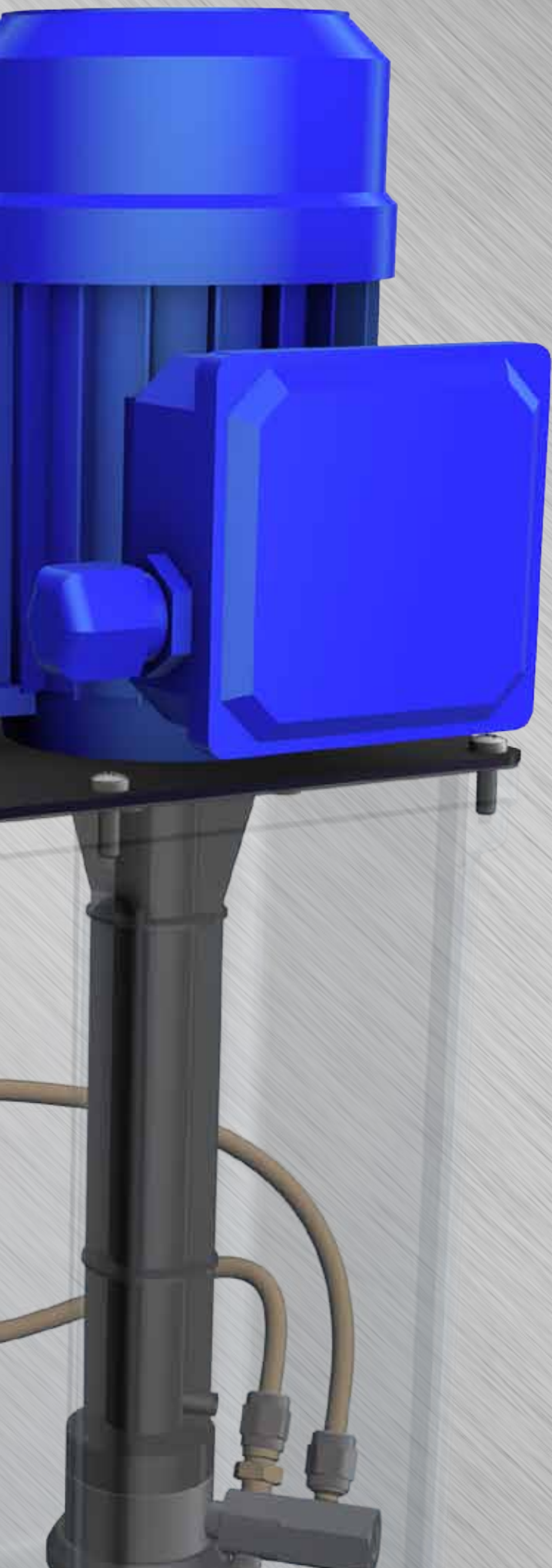

OIL AND SOFT GREASE MPT ELECTRIC PUMPS

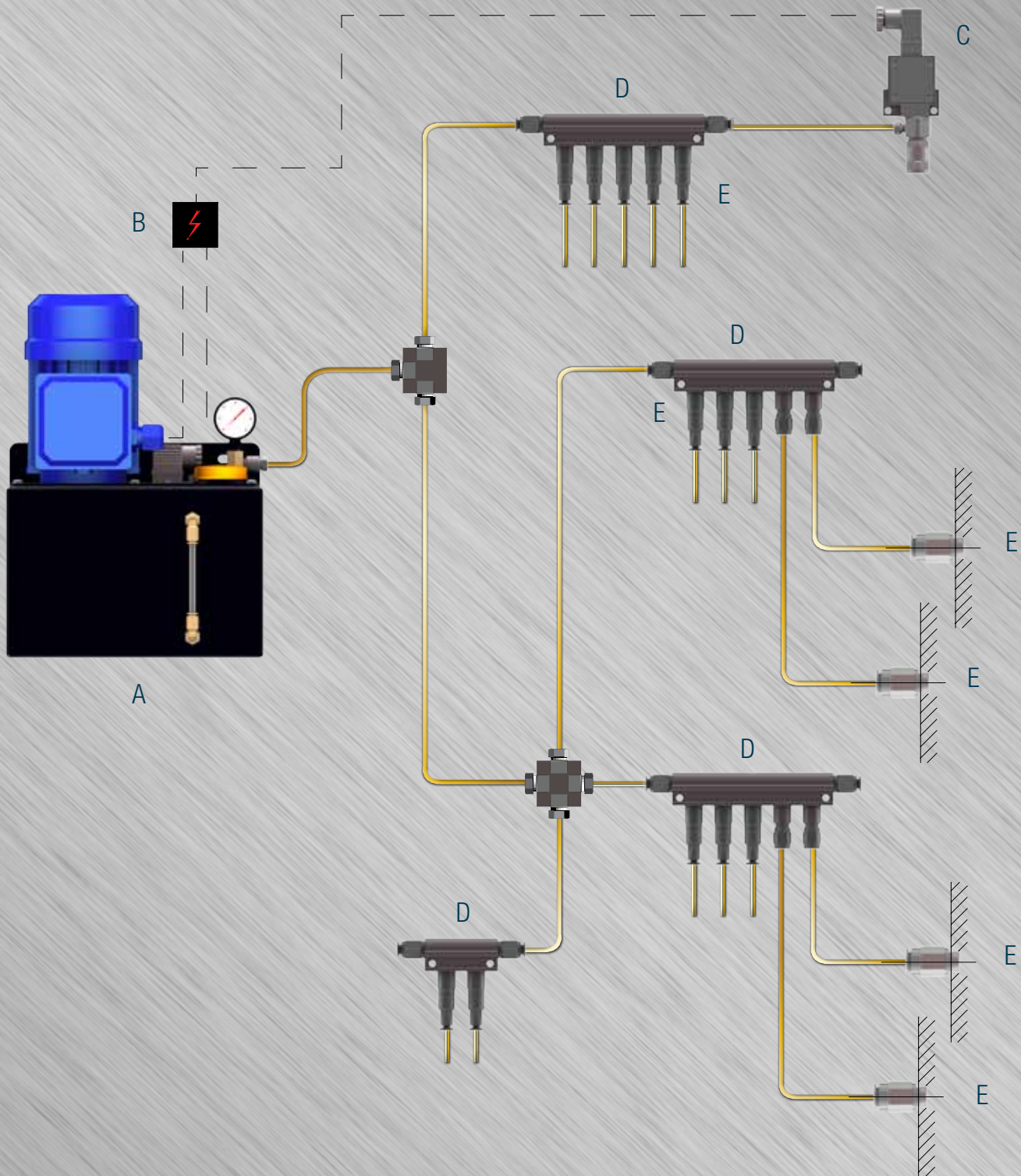

A	MPT ELECTRIC PUMP
B	ELECTRONIC CARD OR PLC
C	PRESSURE SWITCH
D	MANIFOLDS
E	VOLUMETRIC METERING UNITS

OIL AND SOFT GREASE MPT ELECTRIC PUMPS

The gear electric pumps **MPT** are supplied for centralized lubrication system with oil where volumetric metering units are used. The motor pump assembly is located on a steel-sheet angle plate provided with holes for wall mounting. This is also the cover for the reservoir.

The gear pump is provided with a set of valves which carries out priming (the vent valve purge air when the motor starts), releasing (the release valve open when the pump stops to run to release the pressure) and relieving (THE relief valve open to avoid overpressure in the system). THEY ARE provided with suction strainer, low level switch, pressure GAUGE AND strainer filler cup.

Function

At the end of the set pause period operating voltage is applied and the pump motor is switched on. The pump starts running and delivers the oil quantities premeasured in the volumetric metering units to the lubrication points of the machine. The pump stops to run at the end of the set working period and during this period has to be monitored if the pressure switch closes the contact or not. The lubrication cycle is completed. After the pressure in the system has been released, the metering chambers of the volumetric metering units are refilled and further lubrication cycles are repeated in accordance with the pause period set. Intermediate lubrication is possible by briefly pressing pushbutton.

Faults are signaled when no pressure build-up during the lubrication cycle, no pressure release during the pause period or the oil level in the reservoir is low.

Features Electric Motor

SUPPLY VOLTAGE	220-240/380-420
CYCLES	50 Hz
CURRENT	0.64-0.74/0.37-0.46 A
SUPPLY VOLTAGE	254-280/440-480
CYCLES	60 Hz
CURRENT	0.64-0.74/0.37-0.46 A
SUPPLY VOLTAGE	115 V AC
CYCLES	50 Hz o 60 Hz
CURRENT	2.2 A
SUPPLY VOLTAGE	230 V AC
CYCLES	50 Hz o 60 Hz
CURRENT	0.9 A
POWER	90 W
PROTECTION DEGREE	IP - 55
DUTY	CONTINUOUS S1
INSULATING	CLASS F
CONSTRUCTIVE SHAPE	B14
TYPE	MEC - 56

OIL MPT-200 ELECTRIC PUMP



These pumps can be used in small - medium machines with a restrict points number.

Technical Features

DISCHARGE/MINUTE	100 CC
WORKING PRESSURE	5 - 25 bar (70-354 PSI) ADJUSTABLE
RELEASE VALVE	0.7 bar
RESERVOIR	2 L - 3 L - 5 L - 6 L
SUCTION STRAINER	250 MICRON
PRESSURE GAUGE	0 - 60 bar / 0 - 870 PSI
DISCHARGE PORT	M12X1 TUBO 6mm
TEMPERATURE RANGE	FROM -20°C TO +80°C
LUBRICANTS	OIL 50 - 1000 cSt 40°C
LOW LEVEL SWITCH	1.5 A 250 V AC 200 V DC 50 W
MOTOR	SEE TABLE AT PAGE 20

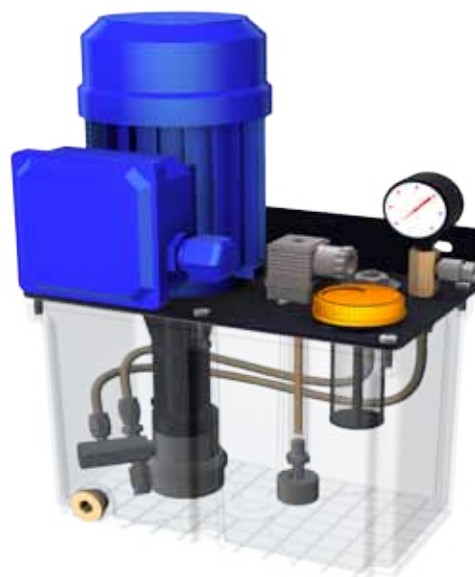

Codes For Order

CODE	PRESSURE	TYPE	RESERVOIR CAPACITY
60.821.0	5 - 25 bar	MPT-2-NY-200-25	2 L NYLON
60.821.1	5 - 25 bar	MPT-3-NY-200-25	3 L NYLON
60.821.2	5 - 25 bar	MPT-6-NY-200-25	6 L NYLON
60.821.3	5 - 25 bar	MPT-3-LA-200-25	5 L METALLIC

On request can be supplied special motor voltages or single phase 115 v – 230 v ac 50/60hz. In this case add the voltage to the order code.

Overall Dimension

PUMP	A	B	C	D	E	F	WEIGHT
MPT-2-NY	160	186	340	128	158	148	4.8 KG
MPT-3-NY	155	181	335	167	165	230	5.3 KG
MPT-6-NY	250	276	430	167	165	230	5.5 KG
MPT-3-LA	156	182	335	167	165	236	7.5 KG

NYLON RESERVOIR

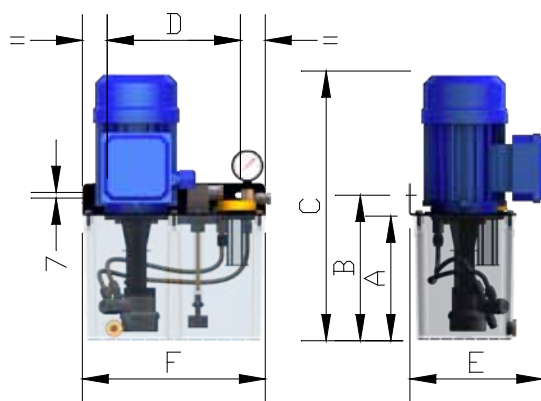

METALLIC RESERVOIR

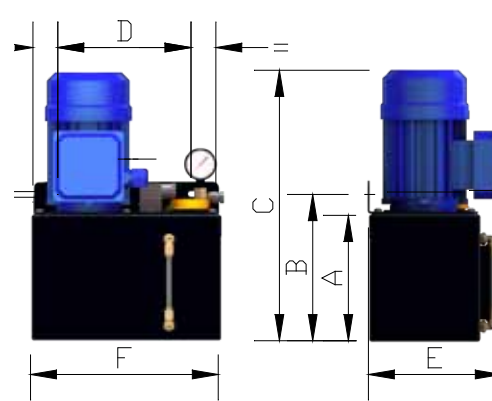

OIL MPT-200/LAM ELECTRIC PUMP

These pumps can be used in small - medium machines with a restrict points number.

Technical Features

DISCHARGE/MINUTE	100 CC
WORKING PRESSURE	5 - 25 bar (70-354 PSI) ADJUSTABLE
RELEASE VALVE	0.7 bar
RESERVOIR	8 L - 12 L - 50 L
SUCTION STRAINER	250 MICRON
PRESSURE GAUGE	0 - 60 bar / 0 - 870 PSI
DISCHARGE PORT	M12X1 TUBE 6mm
TEMPERATURE RANGE	FROM -20°C TO +80°C
LUBRICANTS	OIL 50 - 1000 cSt 40°C
LOW LEVEL SWITCH	1.5 A 250 V AC 200 V DC 50 W
MOTOR	SEE TABLE AT PAGE 20

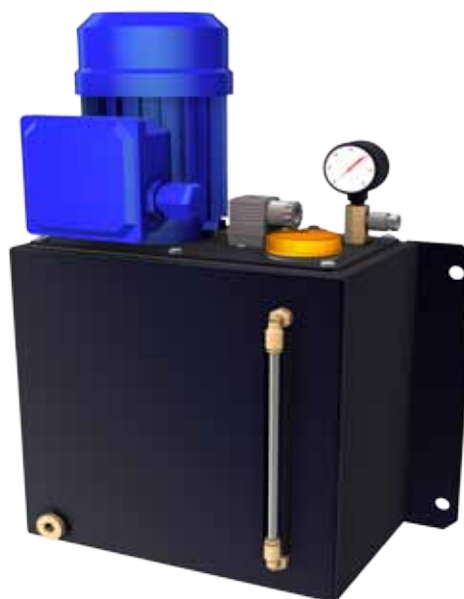

Codes For Order

CODE	PRESSURE	TYPE	RESERVOIR CAPACITY
60.821.4	5 - 25 bar	MPT-6 LA-200-25	8 L
60.821.5	5 - 25 bar	MPT-12 LA-200-25	12 L
60.821.6	5 - 25 bar	MPT-50 LA-200-25	50 L

On request can be supplied special motor voltages or single phase 115 v – 230 v ac 50/60hz. In this case add the voltage to the order code.

Overall Dimension

PUMP	A	B	C	D	E	F	WEIGHT
MPT-6- LA	250	205	430	305	173	330	10 KG
MPT-12-LA	250	205	430	330	196	355	12 KG
MPT-50-LA	400	300	580	530	270	560	18 KG

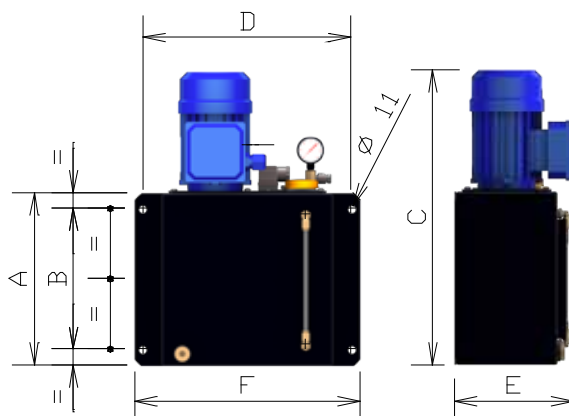

OIL MPT-500 ELECTRIC PUMP



These pumps can be used in medium-big machines with a large points number.

Technical Features

DISCHARGE/MINUTE	100 CC
WORKING PRESSURE	5 - 25 bar (70-354 PSI) ADJUSTABLE 15-50 bar (212-708 PSI) ADJUSTABLE
RELEASE VALVE	0.7 bar
RESERVOIR	3 L - 5 L - 6 L
SUCTION STRAINER	250 MICRON
PRESSURE GAUGE	0 - 60 bar / 0 - 870 PSI
DISCHARGE PORT	M12X1 TUBE 6mm
TEMPERATURE RANGE	FROM -20°C TO +80°C
LUBRICANTS	OIL 50 - 1000 cSt 40°C
LOW LEVEL SWITCH	1.5 A 250 V AC 200 V DC 50 W
MOTOR	SEE TABLE AT PAGE 20



Codes For Order

CODE	PRESSURE	TYPE	RESERVOIR CAPACITY	TYPE	PRESSURE	CODE
60.822.0	5 - 25 bar	MPT-3-NY-500-25	3 L NYLON	MPT-3-NY-500-50	15 - 50 bar	60.822.2
60.822.1	5 - 25 bar	MPT-6-NY-500-25	6 L NYLON	MPT-6-NY-500-50	15 - 50 bar	60.822.3
60.822.4	5 - 25 bar	MPT-3-LA-500-25	5 L METALLIC	MPT-3-LA-500-50	15 - 50 bar	60.822.7

On request can be supplied special motor voltages or single phase 115 v - 230 v ac 50/60hz. in this case add the voltage to the order code.

Overall Dimension

PUMP	A	B	C	D	E	F	WEIGHT
MPT-3-NY	155	181	335	167	165	230	5.3 KG
MPT-6-NY	250	276	430	167	165	230	5.5 KG
MPT-3-LA	156	182	335	167	165	236	7.5 KG

NYLON RESERVOIR

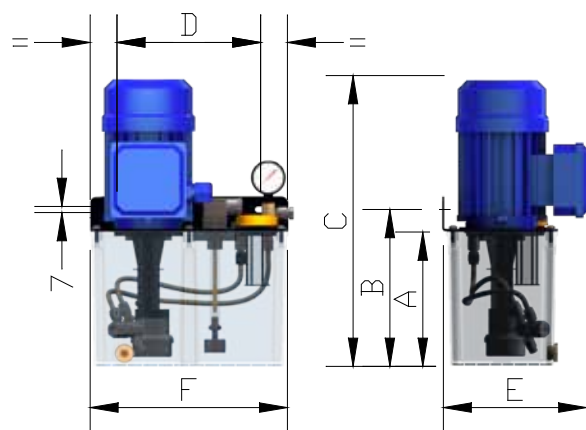

METALLIC RESERVOIR

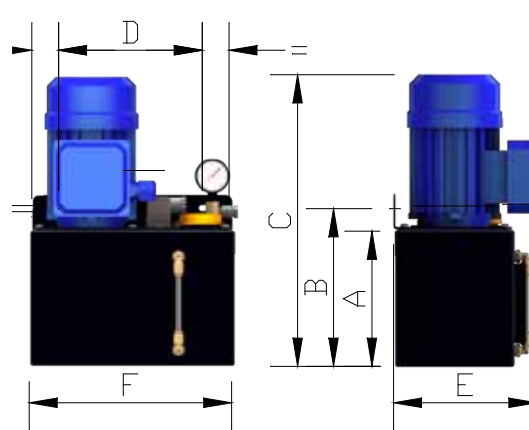

OIL MPT-500/LAM ELECTRIC PUMP

These pumps can be used in medium-big machines with a large points number.

Technical Features

DISCHARGE/MINUTE	500 CC
WORKING PRESSURE	5 - 25 bar (70-354 PSI) REGOLABILE 15-50 bar (212-708 PSI) REGOLABILE
RELEASE VALVE	0.7 bar
RESERVOIR	8 L - 12 L - 50 L
SUCTION STRAINER	250 MICRON
PRESSURE GAUGE	0 - 60 bar / 0 - 870 PSI
DISCHARGE PORT	M12X1 TUBO 6mm
TEMPERATURE RANGE	FROM -20°C TO +80°C
LUBRICANTS	OIL 50 - 1000 cSt 40°C
LOW LEVEL SWITCH	1.5 A 250 V AC 200 V DC 50 W
MOTOR	SEE TABLE AT PAGE 20



Codes For Order

CODE	PRESSURE	TYPE	RESERVOIR CAPACITY	TYPE	PRESSURE	CODE
60.822.5	5 - 25 bar	MPT-6- LA-500-25	8 L	MPT-6-LA- 500-50	15 - 50 bar	60.822.8
60.822.6	5 - 25 bar	MPT-12-LA-500-25	12 L	MPT-12-LA-500-50	15 - 50 bar	60.822.9
60.829.0	5 - 25 bar	MPT-50-LA-500-25	50 L	MPT-50-LA-500-50	15 - 50 bar	60.829.1

On request can be supplied special motor voltages or single phase 115 v - 230 v ac 50/60hz. In this case add the voltage to the order code.

Overall Dimension

PUMP	A	B	C	D	E	F	WEIGHT
MPT-6- LA	250	205	430	305	173	330	10 KG
MPT-12-LA	250	205	430	330	196	355	12 KG
MPT-50-LA	400	300	580	530	270	560	18 KG

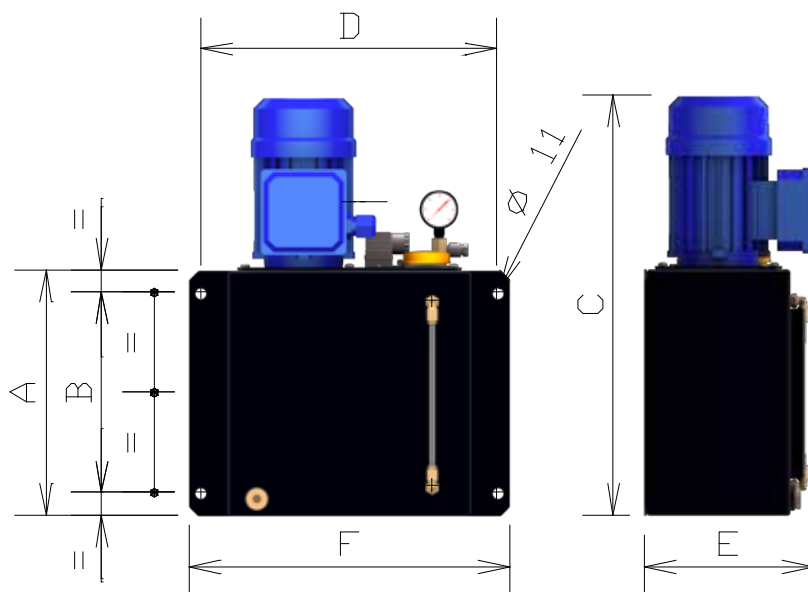

SOFT GREASE MPT-200/G ELECTRIC PUMP



These pumps can be used in small - medium machines with a restrict points number.

Technical Features

DISCHARGE/MINUTE	100 CC
WORKING PRESSURE	5 - 25 bar (70-354 PSI) ADJUSTABLE
RELEASE VALVE	0.7 bar
RESERVOIR	3 L - 5 L - 6 L
SUCTION STRAINER	400 MICRON
PRESSURE GAUGE	0 - 60 bar / 0 - 870 PSI
DISCHARGE PORT	M12X1 TUBE 6mm
TEMPERATURE RANGE	FROM -20°C TO +80°C
LUBRICANTS	SOFT GREASE NLGI 000 - 00
LOW LEVEL SWITCH	Da 10 V A 40 V DC
MOTOR	SEE TABLE AT PAGE 20

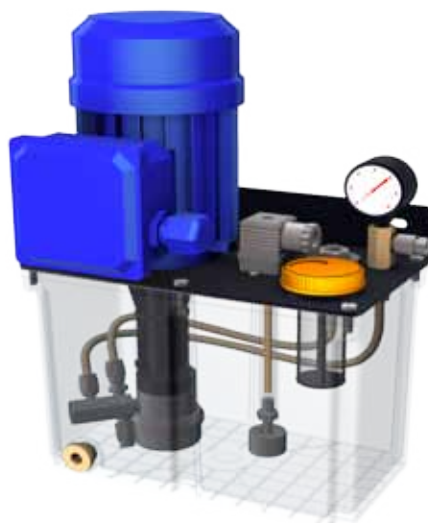

Codes For Order

CODE	PRESSURE	TYPE	RESERVOIR CAPACITY
60.823.1	15 - 50 bar	MPT-3-G-NY-200-50	3 L NYLON
60.823.2	15 - 50 bar	MPT-6-G-NY-200-50	6 L NYLON
60.823.3	15 - 50 bar	MPT-3-G-LA-200-50	5 L METALLIC

On request can be supplied special motor voltages or single phase 115 v - 230 v ac 50/60hz. In this case add the voltage to the order code.

Overall Dimension

PUMP	A	B	C	D	E	F	WEIGHT
MPT-3-G-NY	155	181	335	167	165	230	5.3 KG
MPT-6-G-NY	250	276	430	167	165	230	5.5 KG
MPT-3-G-LA	156	182	335	167	165	236	7.5 KG

NYLON RESERVOIR

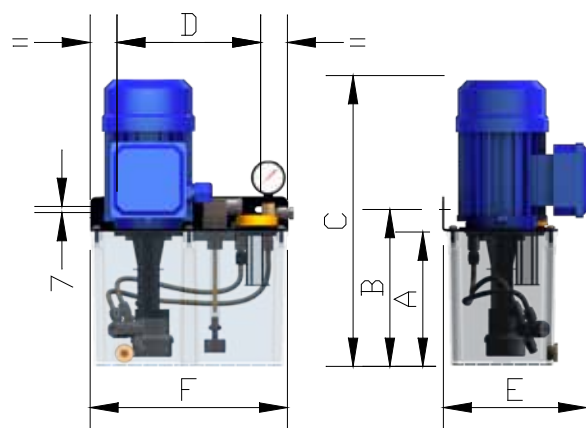

METALLICO RESERVOIR

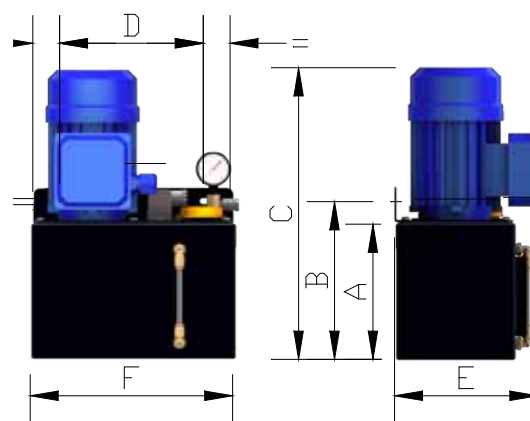

SOFT GREASE MPT-200/G/LAM ELECTRIC PUMP

These pumps can be used in small - medium machines with a restrict points number.

Technical Features

DISCHARGE/MINUTE	100 CC
WORKING PRESSURE	5 - 25 bar (70-354 PSI) ADJUSTABLE
RELEASE VALVE	0.7 bar
RESERVOIR	8 L - 12 L - 50 L
SUCTION STRAINER	400 MICRON
PRESSURE GAUGE	0 - 60 bar / 0 - 870 PSI
DISCHARGE PORT	M12X1 TUBO 6mm
TEMPERATURE RANGE	FROM -20°C TO +80°C
LUBRICANTS	SOFT GREASE NLGI 000 - 00
LOW LEVEL SWITCH	FROM 10 V TO 40 V DC
MOTOR	SEE TABLE AT PAGE 20

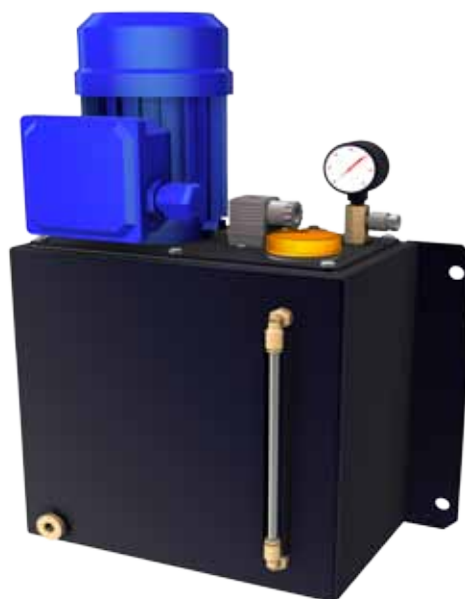

Codes For Order

CODE	PRESSURE	TYPE	RESERVOIR CAPACITY
60.823.4	15 - 50 bar	MPT-6-G-LA-200-50	8 L
60.823.5	15 - 50 bar	MPT-12-G-LA-200-50	12 L
60.823.6	15 - 50 bar	MPT-50-G-LA-200-50	50 L

On request can be supplied special motor voltages or single phase 115 v - 230 v ac 50/60hz. In this case add the voltage to the order code.

Overall Dimension

PUMP	A	B	C	D	E	F	WEIGHT
MPT-6-G-LA	250	205	430	305	173	330	10 KG
MPT-12-G-LA	250	205	430	330	196	355	12 KG
MPT-50-G-LA	400	300	580	530	270	560	18 KG

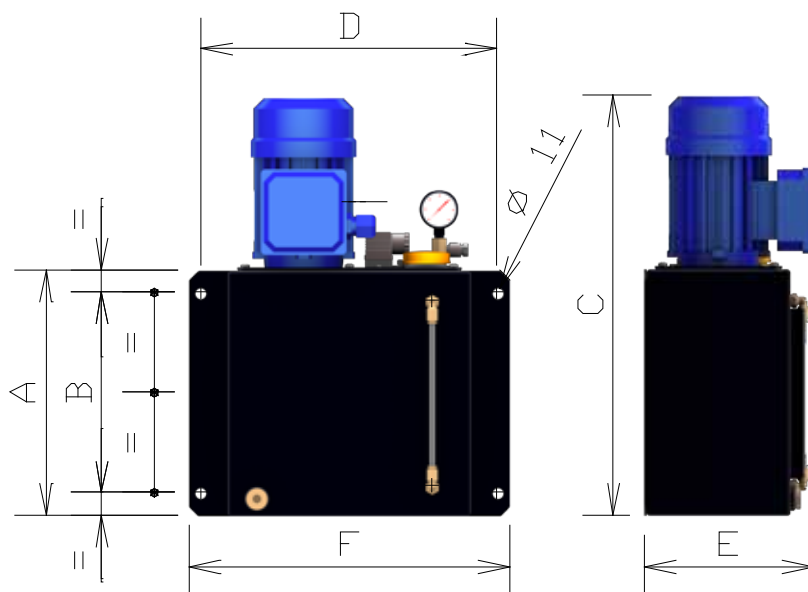

SOFT GREASE MPT-500/G ELECTRIC PUMP



These Pumps Can Be Used In Medium-Big Machines With A Large Points Number.

Technical Features

DISCHARGE/MINUTE	500 CC
WORKING PRESSURE	5 - 25 bar (70-354 PSI) ADJUSTABLE
RELEASE VALVE	0.7 bar
RESERVOIR	3 L - 5 L - 6 L
SUCTION STRAINER	400 MICRON
PRESSURE GAUGE	0 - 60 bar / 0 - 870 PSI
DISCHARGE PORT	M12X1 TUBO 6mm
TEMPERATURE RANGE	FROM -20°C TO +80°C
LUBRICANTS	SOFT GREASE NLGI 000 - 00
LOW LEVEL SWITCH	FROM 10 V TO 40 V DC
MOTOR	SEE TABLE AT PAGE 20

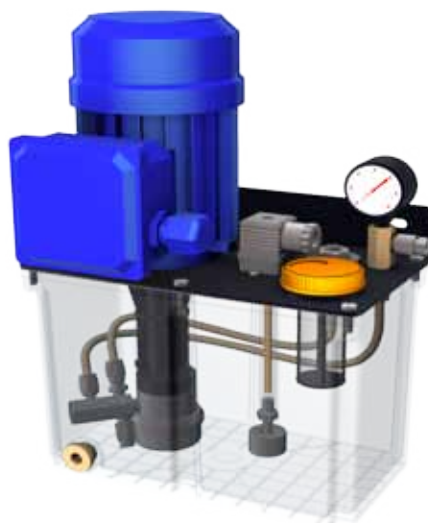

Codes For Order

CODE	PRESSURE	TYPE	RESERVOIR CAPACITY
60.824.2	15 - 50 bar	MPT-3-G-NY-500-50	3 L NYLON
60.824.3	15 - 50 bar	MPT-6-G-NY-500-50	6 L NYLON
60.824.7	15 - 50 bar	MPT-3-G-LA-500-50	5 L METALLIC

On request can be supplied special motor voltages or single phase 115 v - 230 v ac 50/60hz. In this case add the voltage to the order code.

Overall Dimension

PUMP	A	B	C	D	E	F	WEIGHT
MPT-3-G-NY	155	181	335	167	165	230	5.3 KG
MPT-6-G-NY	250	276	430	167	165	230	5.5 KG
MPT-3-G-LA	156	182	335	167	165	236	7.5 KG

NYLON RESERVOIR

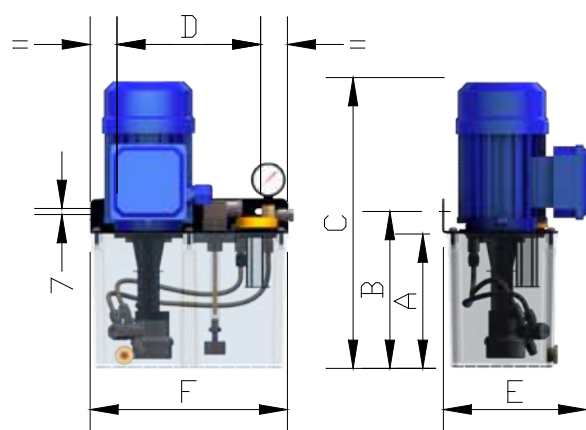

METALLICO RESERVOIR

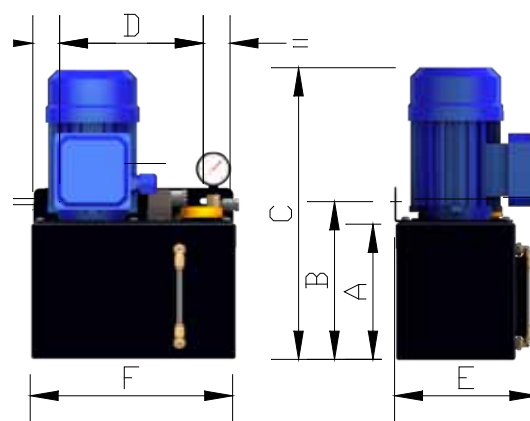

SOFT GREASE MPT-500/G/LAM ELECTRIC PUMP

These pumps can be used in medium-big machines with a large points number.

Technical Features

DISCHARGE/MINUTE	500 CC
WORKING PRESSURE	5 - 25 bar (70-354 PSI) ADJUSTABLE
RELEASE VALVE	0.7 bar
RESERVOIR	8 L - 12 L - 50 L
SUCTION STRAINER	400 MICRON
PRESSURE GAUGE	0 - 60 bar / 0 - 870 PSI
DISCHARGE PORT	M12X1 TUBE 6mm
TEMPERATURE RANGE	FROM -20°C TO +80°C
LUBRICANTS	SOFT GREASE NLGI 000 - 00
LOW LEVEL SWITCH	FROM 10 V TO 40 V DC
MOTOR	SEE TABLE AT PAGE 20



Codes For Order

CODE	PRESSURE	TYPE	RESERVOIR CAPACITY
60.824.8	15 - 50 bar	MPT-6-G-LA-500-50	8 L
60.824.9	15 - 50 bar	MPT-12-G-LA-500-50	12 L
60.829.3	15 - 50 bar	MPT-50-G-LA-500-50	50 L

On request can be supplied special motor voltages or single phase 115 v - 230 v ac 50/60hz. In this case add the voltage to the order code.

Overall Dimension

PUMP	A	B	C	D	E	F	WEIGHT
MPT-6-G-LA	250	205	430	305	173	330	10 KG
MPT-12-G-LA	250	205	430	330	196	355	12 KG
MPT-50-G-LA	400	300	580	530	270	560	18 KG

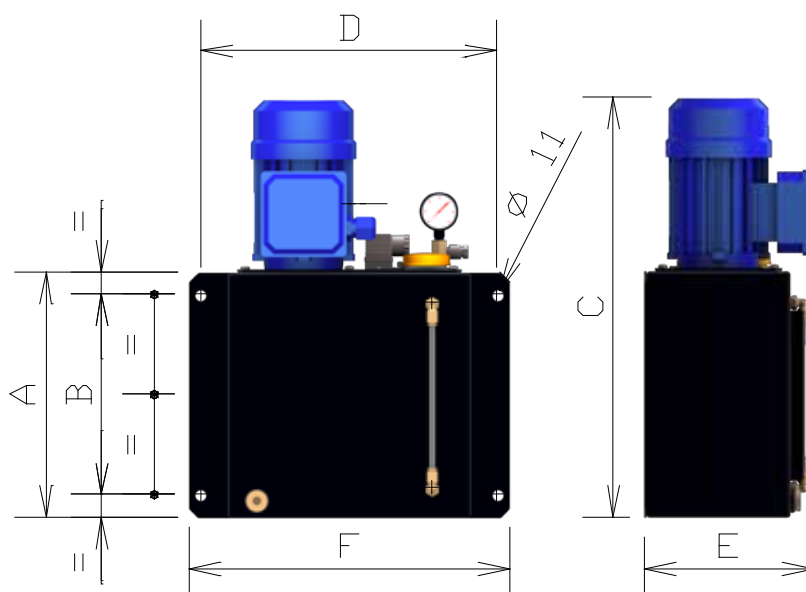

MPT-200 E MPT-500 WITHOUT RESERVOIR

Technical Features

DISCHARGE/MINUTE	100 CC O 500 CC
WORKING PRESSURE	5 - 25 bar (70-354 PSI) ADJUSTABLE 15-50 bar (212-708 PSI) ADJUSTABLE
RELEASE VALVE	0.7 bar
SUCTION STRAINER	250 O 400 MICRON
PRESSURE GAUGE	0 - 60 bar / 0 - 870 PSI
DISCHARGE PORT	M12X1 TUBE 6mm
TEMPERATURE RANGE	FROM -20°C TO +80°C
LUBRICANTS	OIL 50 - 1000 cSt 40°C SOFT GREASE NLGI 000 - 00
LOW LEVEL SWITCH CAPACITY LOW LEVEL SWITCH	1.5 A 250 V AC 200 V DC 50 W FROM 10 V TO 40 V DC
MOTOR	SEE TABLE AT PAGE 20



Codes For Order

CODE	PRESSURE	TYPE	RESERVOIR CAPACITY	TYPE	PRESSURE	CODE
60.825.2	5 - 25 bar	MPT-500 S/S O 145	60.826.5	MPT-500 S/S G 240	15 - 50 bar	60.822.2
60.825.3	5 - 25 bar	MPT-500 S/S O 240	60.825.0	MPT-200 S/S O 145	5 - 25 bar	60.822.3
60.825.4	15 - 50 bar	MPT-500 S/S O 145	60.825.1	MPT-200 S/S O 240	5 - 25 bar	60.822.7
60.825.5	15 - 50 bar	MPT-500 S/S O 240	60.826.0	MPT-200 S/S G 145	15 - 50 bar	60.822.3
60.826.4	15 - 50 bar	MPT-500 S/S G 145	60.826.1	MPT-200 S/S G 240	15 - 50 bar	60.822.7
60.822.1	5 - 25 bar	MPT-6-NY-500-25	6 L NYLON	MPT-6-NY-500-50	15 - 50 bar	60.822.3

On request can be supplied special motor voltages or single phase 115 v – 230 v ac 50/60hz. In this case add the voltage to the order code.

Overall Dimension

PUMP	H	BAR	PUMP	H	BAR
MPT-500 S/S O	145	5 - 25 bar	MPT-500 S/S G	240	15 - 50 bar
MPT-500 S/S O	240	5 - 25 bar	MPT-200 S/S O	145	5 - 25 bar
MPT-500 S/S O	145	15 - 50 bar	MPT-200 S/S O	240	5 - 25 bar
MPT-500 S/S O	240	15 - 50 bar	MPT-200 S/S G	145	15 - 50 bar
MPT-500 S/S G	145	15 - 50 bar	MPT-200 S/S G	240	15 - 50 bar

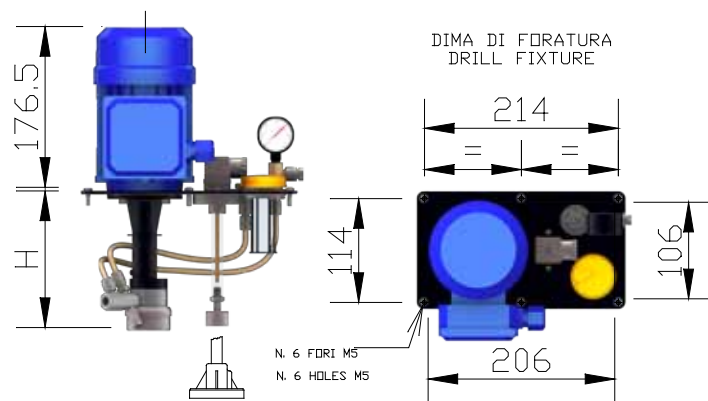



POMAC
LUB SERVICES BVBA

Kortrijkstraat 187 B-8770 Ingelmunster
Tel. +32 (0)51 316 205 - Fax +32 (0)51 309 621 info@pomac.be - www.pomac.be

CME SINGLE PHASE GEAR PUMPS

CME pumps have been precisely tailored to meet the widest possible range of operating requirements. **CME** pumps provide metered lubrication for medium or big machine with many points. **CME** pumps handle oils from 50 to 1000 cst and soft-grease with nlgi 000-00. **CME** electric pumps have been developed for single line system to feed positive displacement injectors (control response direct or indirect). cme has the gear pump with a discharge of 100 cc/1', the single phase motor 115 v or 230 v ac (on request 24 v dc), the low level switch, the integrated electronic card (on request) and the pressure switch (on request) inside in the housing. the impact resistant transparent reservoir has a capacity of 3.6 liters or 6 liters. the gear pump is complete of valves to relief - purge air and by/pass. the integrated electronic card controls and supervises the system in many ways. it has the possibility to adjust the pause time (from 2.5 minutes to 21 hours) and the working time (from 5 seconds to 90 seconds) by means of dip-switches, to control the system by means of a pressure switch (inside or outside), to select if is required or not the pre-lubrication function and to have the remote alarm signal.

Features

MOTOR 115 V AC OR 230 V AC	SINGLE-PHASE
POWER RATING	110 W
CURRENT	0.75 A (230 V) 1.5 A (115 V)
PROTECTION	IP-33 CLASS B
MOTOR 24 V DC	30 W – 1.5 A
DISCHARGE/1'	100 CC
WORKING PRESSURE	24 BAR MAX FOR OIL 0 BAR MAX PER GRASSELLO
RESERVOIR	NYLON 3.6 OR 6 LITERS
LUBRICANTS	OIL 50 - 1000 cSt SOFT GREASE NLGI 000 - 00
SUCTION STRAINER	250 MICRON
LOW LEVEL RATINGS	OIL 0.5 A - 250 V AC - 150 V DC SOFT-GREASE 2 A 24 V DC
PRESSURE GAUGE	0-60 BAR ON REQUEST
PAUSE TIME	FROM 2.5 MINUTES TO 21 HOURS
WORKING TIME	FROM 5 TO 90 SECONDS
DISCHARGE PORT	M12X1 TUBE 6 MM
PUSH BUTTON	EXTRA CYCLES - RESET
GREEN LAMP	ON LINE
YELLOW LAMP	WORK PUMP
RED LAMP	LOW-LEVEL ALARM PRESSURE ALARM
OPERATING TEMPERATURE	FROM -10 °C TO +60 °C

If engine temperature reaches 150 °C occurs protection by mean of a sensor which stops and starts engine up again until the temperature drops below 150 °C.



The **CME** use the same electronic timer with control or without control. It is only necessary to change the jumper j2 position (see the next pages). If the jumper j2 is in the position “timer with control” has to be installed a pressure switch otherwise a fault will be indicated from the electronic card after the first cycle and the pump will stop to work.

The jumper j1 is an additional feature and has the ability to select whether the system operates whenever the controller is switched on (prelube) or not. The “prelube required” is very useful when has to be used a long pause time or the machine is being turned off for long time. The electronic timer has no memory so the working time resets during power interruptions.

Pressing the push button on the electronic timer will end the pause period and start the pump that will run for the working period. It is also used to clear a system fault indication (from the pressure switch or the low level switch).

To avoid to stop the pump before the most far metering valves have worked, specially the cme with inside pressure switch and the cme with electronic timer with control continue to work for the set working period and after will monitor if the pressure switch closed the contact or not.

For the layout with outside drive a plc or a control board is needed for adjusting the working and pause time. In this case the minimum pause period has to be 5 minutes and the maximum working period has to be 60 seconds. If it is necessary to have a pause period of 2.5 minutes the maximum working period has to be 45 seconds. When this layout has a pressure switch inside the plc or the control board have to monitor the contacts change of the pressure switch and the low level switch (all the layouts have a low level switch).

IMPORTANT: when the low level switch closes the contacts the red led turns on. The pump will continue to work without problem.

CME SINGLE PHASE GEAR PUMPS

There Are 6 Layout For The Cme Gear Pumps

FUNCTIONS	LAYOUT
<p>THE LAYOUT WITHOUT ELECTRONIC TIMER IS CALLED CE AND HAS TO BE DRIVEN FROM A PLC OR A CONTROL BOARD. THE ELECTRICAL LINKS HAVE TO BE MADE FOR THE LOW LEVEL SWITCH AND THE TENSION.</p>	<p>CME CE</p>
<p>THE LAYOUT WITH ELECTRONIC TIMER WITHOUT CONTROL IS CALLED SC. THE PUMP WORKS ON THE BASIS OF A PAUSE AND WORKING PERIOD. THE ELECTRICAL LINKS HAVE TO BE MADE FOR THE TENSION AND THE LOW LEVEL SWITCH (IF IT IS NECESSARY TO HAVE THIS SIGNAL IN SOME OTHER SITE OF THE MACHINE).</p>	<p>CME SC</p>
<p>THE LAYOUT WITHOUT ELECTRONIC TIMER AND WITH PRESSURE SWITCH INSIDE IS CALLED CE + PFL (PRESSURE SWITCH INSIDE) AND HAS TO BE DRIVEN FROM A PLC OR A CONTROL BOARD. THE ELECTRICAL LINKS HAVE TO BE MADE FOR THE LOW LEVEL SWITCH, THE TENSION AND THE PRESSURE SWITCH.</p>	<p>CME + PFL</p>
<p>THE LAYOUT WITH ELECTRONIC TIMER WITH CONTROL AND WITH PRESSURE SWITCH INSIDE IS CALLED CC + PFL (PRESSURE SWITCH INSIDE). THE ELECTRICAL LINKS HAVE TO BE MADE FOR THE TENSION AND THE LOW LEVEL SWITCH (IF IT IS NECESSARY TO HAVE THIS SIGNAL IN SOME OTHER SITE OF THE MACHINE).</p>	<p>CME CC + PFL</p>
<p>THE LAYOUT WITHOUT ELECTRONIC TIMER WITH PRESSURE SWITCH INSIDE AND COMPLETE OF THE PUSH BUTTON IS CALLED CE + PLUS + PFL (PRESSURE SWITCH INSIDE). THE ELECTRICAL LINKS HAVE TO BE MADE FOR THE TENSION, THE PRESSURE SWITCH AND THE LOW LEVEL SWITCH.</p>	<p>CME CE + PULS + PFL</p>
<p>THE LAYOUT WITHOUT ELECTRONIC TIMER AND COMPLETE WITH PUSH BUTTON IS CALLED CE + PULS AND HAS TO BE DRIVEN FROM A PLC OR A CONTROL BOARD. THE ELECTRICAL LINKS HAVE TO BE MADE FOR THE LOW LEVEL SWITCH AND THE TENSION.</p>	<p>CME CE + PULS</p>

CME FOR OIL WITH MOTOR 115 V AC OR 230 V AC

Codes For Order

PUMP	TYPE			RESERVOIR	
00.870.0	CME	CE	115 V	3.6 L	WITHOUT TIMER
00.870.1	CME	CE	230 V	3.6 L	
00.870.2	CME	SC	115 V	3.6 L	WITH TIMER FOR WORKING AND PAUSE TIME
00.870.3	CME	SC	230 V	3.6 L	
00.870.4	CME	CE + PFL	115 V	3.6 L	WITHOUT TIMER - WITH PRESSURE SWITCH
00.870.5	CME	CE + PFL	230 V	3.6 L	
00.870.6	CME	CC + PFL	115 V	3.6 L	WITH TIMER AND PRESSURE SWITCH
00.870.7	CME	CC + PFL	230 V	3.6 L	
00.870.8	CME	CE + PULS + PFL	115 V	3.6 L	WITHOUT TIMER - WITH PUSH BUTTON AND PRESSURE SWITCH
00.870.9	CME	CE + PULS + PFL	230 V	3.6 L	
00.873.5	CME	CE + PULS	115 V	3.6 L	WITHOUT TIMER - WITH PUSH BUTTON
00.873.6	CME	CE + PULS	230 V	3.6 L	
00.874.5	CME	CE	115 V	6 L	WITHOUT TIMER
00.874.6	CME	CE	230 V	6 L	
00.874.7	CME	SC	115 V	6 L	WITH TIMER FOR WORKING AND PAUSE TIME
00.874.8	CME	SC	230 V	6 L	
00.874.9	CME	CE + PFL	115 V	6 L	WITHOUT TIMER - WITH PRESSURE SWITCH
00.875.0	CME	CE + PFL	230 V	6 L	
00.875.1	CME	CC + PFL	115 V	6 L	WITH TIMER AND PRESSURE SWITCH
00.875.2	CME	CC + PFL	230 V	6 L	
00.875.3	CME	CE + PULS + PFL	115 V	6 L	WITHOUT TIMER - WITH PUSH BUTTON AND PRESSURE SWITCH
00.875.4	CME	CE + PULS + PFL	230 V	6 L	
00.875.5	CME	CE + PULS	115 V	6 L	WITHOUT TIMER - WITH PUSH BUTTON
00.875.6	CME	CE + PULS	230 V	6 L	

EQUIPMENT ON REQUEST	CODE
PRESSURE GAUGE 0 - 60 BAR	46.300.0

Overall Dimension

3,6 LITRI

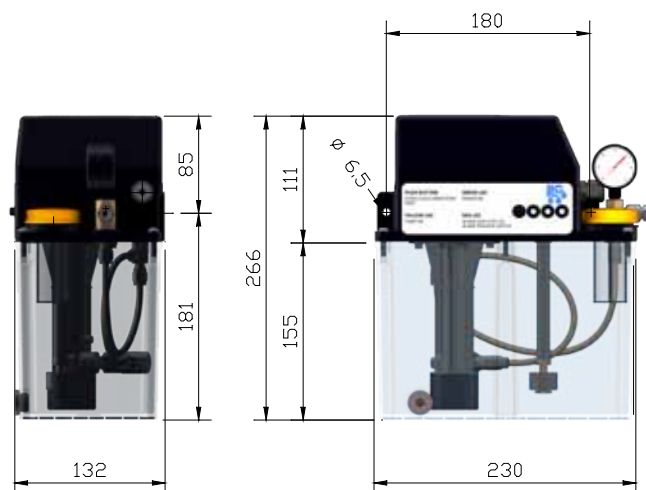

6 LITRI



CME FOR SOFT GREASE WITH MOTOR 115 V AC OR 230 V AC
Codes For Order

PUMP		TYPE		RESERVOIR	
00.872.0	CME-G	CE	115 V	3.6 L	WITHOUT TIMER
00.872.1	CME-G	CE	230 V	3.6 L	
00.872.2	CME-G	SC	115 V	3.6 L	WITH TIMER FOR WORKING AND PAUSE TIME
00.872.3	CME-G	SC	230 V	3.6 L	
00.872.4	CME-G	CE + PFL	115 V	3.6 L	WITHOUT TIMER - WITH PRESSURE SWITCH
00.872.5	CME-G	CE + PFL	230 V	3.6 L	
00.872.6	CME-G	CC + PFL	115 V	3.6 L	WITH TIMER AND PRESSURE SWITCH
00.872.7	CME-G	CC + PFL	230 V	3.6 L	
00.872.8	CME-G	CE + PULS + PFL	115 V	3.6 L	WITHOUT TIMER - WITH PUSH BUTTON AND PRESSURE SWITCH
00.872.9	CME-G	CE + PULS + PFL	230 V	3.6 L	
00.873.9	CME-G	CE + PULS	115 V	3.6 L	WITHOUT TIMER - WITH PUSH BUTTON
00.874.0	CME-G	CE + PULS	230 V	3.6 L	
00.877.0	CME-G	CE	115 V	6 L	WITHOUT TIMER
00.877.1	CME-G	CE	230 V	6 L	
00.877.2	CME-G	SC	115 V	6 L	WITH TIMER FOR WORKING AND PAUSE TIME
00.877.3	CME-G	SC	230 V	6 L	
00.877.4	CME-G	CE + PFL	115 V	6 L	WITHOUT TIMER - WITH PRESSURE SWITCH
00.877.5	CME-G	CE + PFL	230 V	6 L	
00.877.6	CME-G	CC + PFL	115 V	6 L	WITH TIMER AND PRESSURE SWITCH
00.877.7	CME-G	CC + PFL	230 V	6 L	
00.877.8	CME-G	CE + PULS + PFL	115 V	6 L	WITHOUT TIMER - WITH PUSH BUTTON AND PRESSURE SWITCH
00.877.9	CME-G	CE + PULS + PFL	230 V	6 L	
00.878.0	CME-G	CE + PULS	115 V	6 L	WITHOUT TIMER - WITH PUSH BUTTON
00.878.1	CME-G	CE + PULS	230 V	6 L	

EQUIPMENT ON REQUEST	CODE
PRESSURE GAUGE 0 - 60 BAR	46.300.0

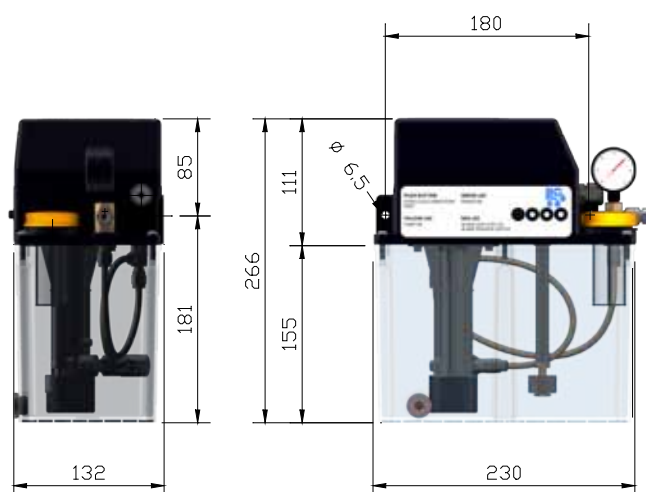
Overall Dimension
3,6 LITRI

6 LITRI

CME FOR OIL (CME) AND CME FOR SOFT GREASE (CME-G) WITH MOTOR 24 V DC
Codes For Order

PUMP		TYPE	RESERVOIR	
00.871.4	CME	CE	3,6 L	WITHOUT TIMER
00.871.5	CME-G	CE	3,6 L	
80.872.0	CME	SC	3,6 L	WITH TIMER FOR WORKING AND PAUSE TIME
80.872.1	CME-G	SC	3,6 L	
00.871.6	CME	CE + PFL	3,6 L	WITHOUT TIMER - WITH PRESSURE SWITCH
00.871.7	CME-G	CE + PFL	3,6 L	
80.872.2	CME	CC + PFL	3,6 L	WITH TIMER AND PRESSURE SWITCH
80.872.3	CME-G	CC + PFL	3,6 L	
00.879.1	CME	CE + PULS + PFL	3,6 L	WITHOUT TIMER - WITH PUSH BUTTON AND PRESSURE SWITCH
00.879.2	CME-G	CE + PULS + PFL	3,6 L	
80.871.9	CME	CE + PULS	3,6 L	WITHOUT TIMER - WITH PUSH BUTTON
00.879.9	CME-G	CE + PULS	3,6 L	
00.875.7	CME	CE	6 L	WITHOUT TIMER
00.875.8	CME-G	CE	6 L	
80.872.4	CME	SC	6 L	WITH TIMER FOR WORKING AND PAUSE TIME
80.872.5	CME-G	SC	6 L	
00.875.9	CME	CE + PFL	6 L	WITHOUT TIMER - WITH PRESSURE SWITCH
00.876.8	CME-G	CE + PFL	6 L	
80.872.6	CME	CC + PFL	6 L	WITH TIMER AND PRESSURE SWITCH
80.872.7	CME-G	CC + PFL	6 L	
00.876.9	CME	CE + PULS + PFL	6 L	WITHOUT TIMER - WITH PUSH BUTTON AND PRESSURE SWITCH
00.879.3	CME-G	CE + PULS + PFL	6 L	
00.879.4	CME	CE + PULS	6 L	WITHOUT TIMER - WITH PUSH BUTTON
00.879.8	CME-G	CE + PULS	6 L	

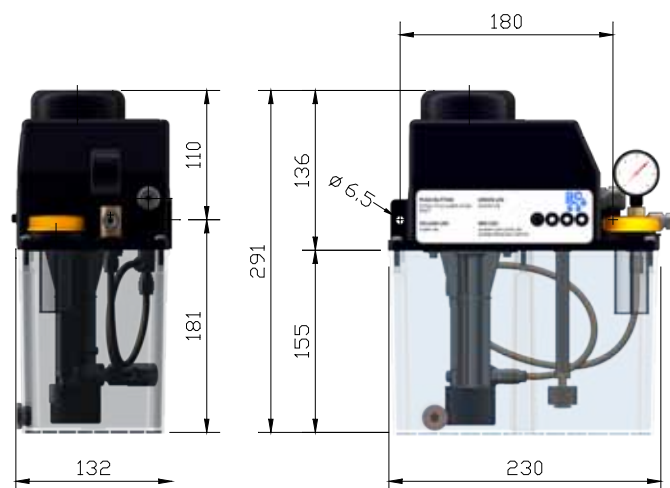
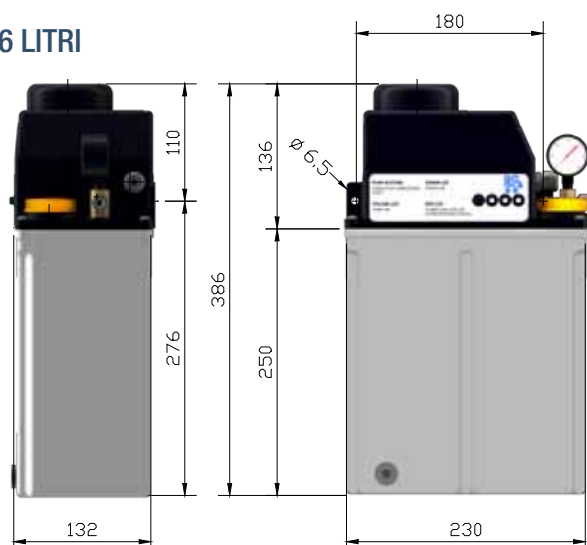
EQUIPMENT ON REQUEST	CODE
PRESSURE GAUGE 0 - 60 BAR	46.300.0

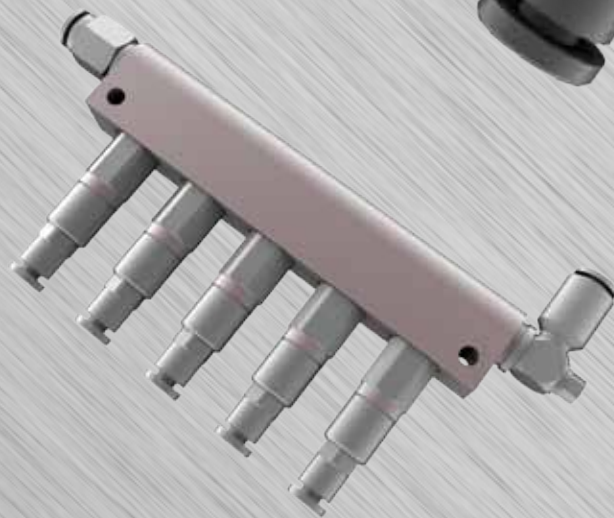
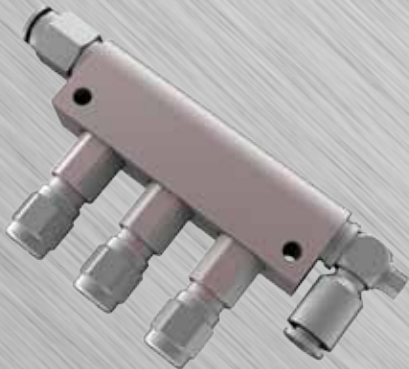
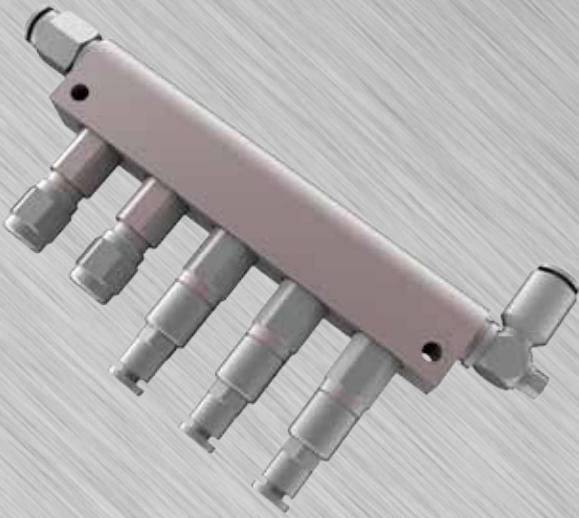
Overall Dimension
3,6 LITRI

6 LITRI





The lubricant delivery units are manually, pneumatically or electrically actuated and the lubricant is metered out by mean of the metering valves installed in the tubing system. The metering valves are produced with different discharges to supply every lubrication point with the requisite amount of lubricant per stroke or pump work cycle. It is absolutely necessary to use a perfect clean lubricant for a correct valve operation.

Ilcomatic-3 Metering Valves

The delivery of lubricant is affected when the pump is on and the necessary pressure is reached also with a very slow thrust. When the pump stops and the pressure is consequently released into the main lines, the valves are ready for the subsequent delivery. They can be used for medium-big machine with a large point numbers.

LUBRICANT	Oil 32 cst – 2000 cst Soft-grease nlgi 000-00
WORKING PRESSURE	From 12 bar to 50 bar for the valves with discharge 15-30-60-100-160-500-750 and 1000 mm ³ From 15 to 50 bar for the valves with discharge 200-300 mm ³
MINIMUM PAUSE TIME	10 seconds for oils from 32 to 250 cs 200 seconds for oils from 260 to 2000 cst and soft grease NLGI 00
RELEASE MAXIMUM PRESSURE	4 bar for the discharge 15-30-60-100-160 mm ³ 3.5 bar for the discharge 200-300 mm ³ 2.5 bar for the discharge 500-750-1000 mm ³
WORKING TEMPERATURE	From 0 °C to 80 °C
SEAL	NBR On request viton

VERY IMPORTANT: ABOVE DATA ARE ONLY THEORETICAL AND THEY ARE SUBJECTS TO VARIATIONS ON THE BASE OF THE SYSTEM LENGTHS, THE MAIN LINE DIMENSIONS, THE LUBRICANT TYPES AND THE WORKING TEMPERATURE

METERING VALVES

The **ILCOMATIC-3** metering valves are supplied for centralized lubrication systems with oil or soft grease. they can be installed on one-side or two-side manifolds or directly on the lubrication points. for a correct operation the line pressure has not to be lower than 15 bar and the delivery thrust can be very low.

Flow Diagram

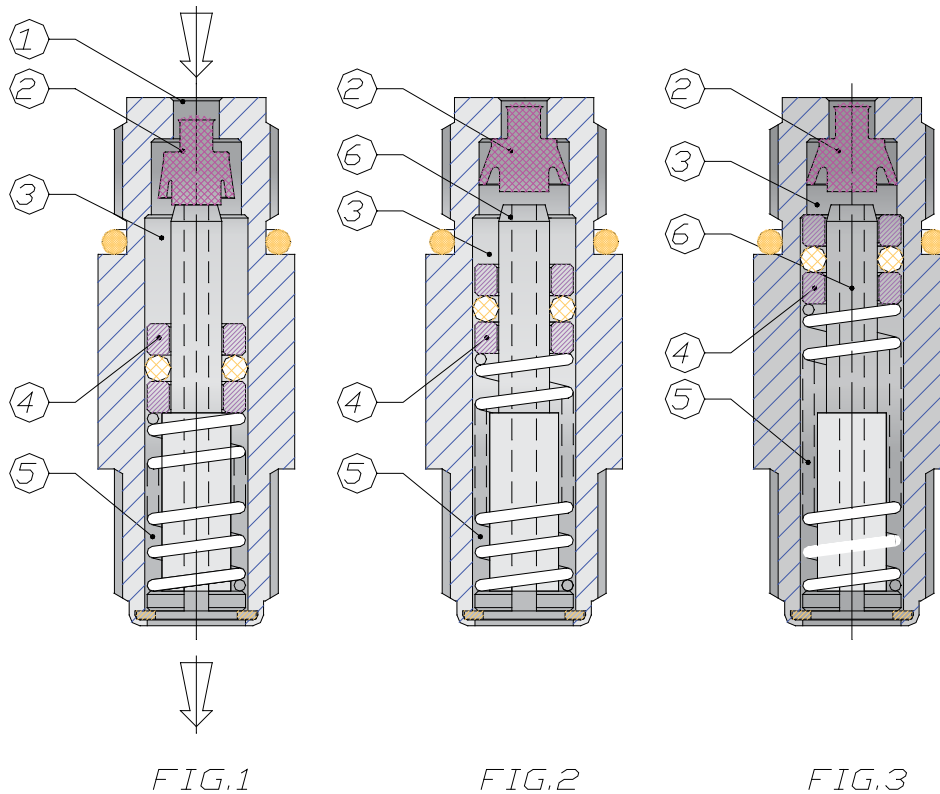

FIG 1

BY ACTUATING THE PUMP, THE PRESSURE, WHICH THROUGH THE NARROWING OF THE VALVE LIP (2) ENABLES THE LUBRICANT TO ENTER INTO THE VANE (3), GETS TO THE HOLE (1) AND CONSEQUENTLY MOVES THE PISTON (4), WHICH DELIVERS THE FLOW PREVIOUSLY STORED IN THE VANE (5).

FIG 2

DURING THE RELEASE ACTION THE PISTON (4), WHICH IS PUSHED BY THE SPRING, COMES BACK TO ITS INITIAL POSITION. WITH THIS MOTION IT TAKES THE SEALING VALVE AWAY (2), THE HOLE (6) OPENS SO TO PERMIT TO THE LUBRICANT TO MOVE FROM VANE (3) TO (5).

FIG 3

THE PISTON (4) HAS COMPLETED ITS STROKE. THE LUBRICANT HAS COMPLETELY MOVED FROM VANE (3) TO (5). THE SEALING VALVE (2) HAS CLOSED THE HOLE (6) AND THE DOSING VALVE IS SO READY FOR THE SUBSEQUENT CYCLE.

METERING VALVES M10x1 (M) – M10x1 (M) FOR MANIFOLD

THE SEALS ARE IN NBR. ON REQUEST IS POSSIBLE TO SUPPLY THE VALVES WITH VITON SEALS. HAVE TO BE ADD .V TO THE CODE

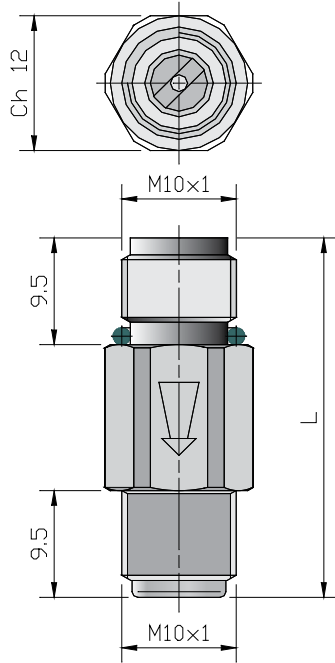

CODE	MARKING	METERED Q.TY	L
02.709.0	15	15 MM ³	32 MM
02.709.1	30	30 MM ³	32 MM
02.709.2	60	60 MM ³	32 MM
02.709.3	100	100 MM ³	32 MM
02.709.4	160	160 MM ³	32 MM
02.709.5	200	200 MM ³	37.6 MM
02.709.6	300	300 MM ³	37.6 MM

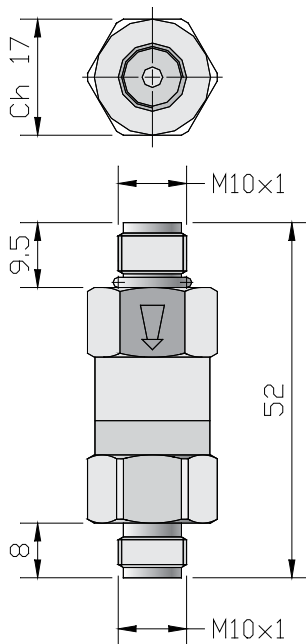

CODE	MARKING	METERED Q.TY	L
02.601.6	6	500 MM ³	32 MM
02.601.7	7	750 MM ³	32 MM
02.601.8	8	1000 MM ³	32 MM

METERING VALVES M10x1 (M) – PUSH-IN FOR MANIFOLD

THE SEALS ARE IN NBR. ON REQUEST IS POSSIBLE TO SUPPLY THE VALVES WITH VITON SEALS. HAVE TO BE ADD .V TO THE CODE

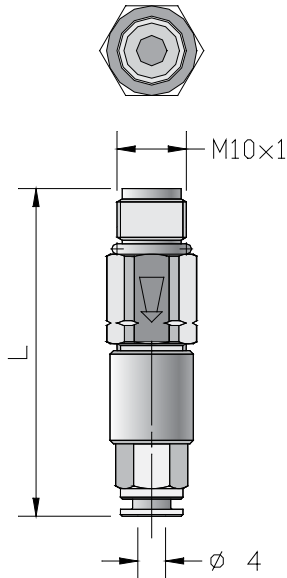

CODE	MARKING	METERED Q.TY	L
02.710.0	15	15 MM ³	51 MM
02.710.1	30	30 MM ³	51 MM
02.710.2	60	60 MM ³	51 MM
02.710.3	100	100 MM ³	51 MM
02.710.4	160	160 MM ³	51 MM
02.710.5	200	200 MM ³	56.5 MM
02.710.6	300	300 MM ³	56.5 MM

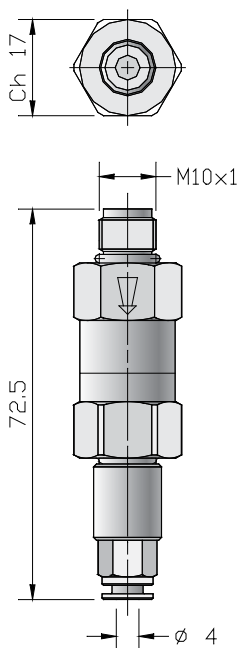

CODE	MARKING	METERED Q.TY	L
02.710.7	6	500 MM ³	32 MM
02.710.8	7	750 MM ³	32 MM
02.710.9	8	1000 MM ³	32 MM

METERING VALVES M10x1 (M) – M8x1 (F) FOR MANIFOLD

THE SEALS ARE IN NBR. ON REQUEST IS POSSIBLE TO SUPPLY THE VALVES WITH VITON SEALS. HAVE TO BE ADD .V TO THE CODE

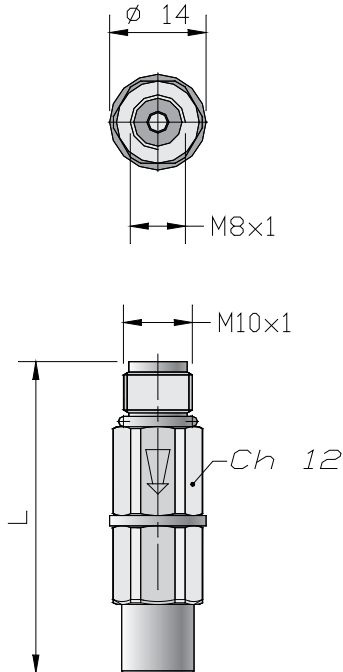

CODE	MARKING	METERED Q.TY	L
02.713.0	15	15 MM ³	45.5 MM
02.713.1	30	30 MM ³	45.5 MM
02.713.2	60	60 MM ³	45.5 MM
02.713.3	100	100 MM ³	45.5 MM
02.713.4	160	160 MM ³	45.5 MM
02.713.5	200	200 MM ³	51.1 MM
02.713.6	300	300 MM ³	51.1 MM

LAYOUT FOR ILCOMATIC-3 METERING VALVES FOR MANIFOLDS

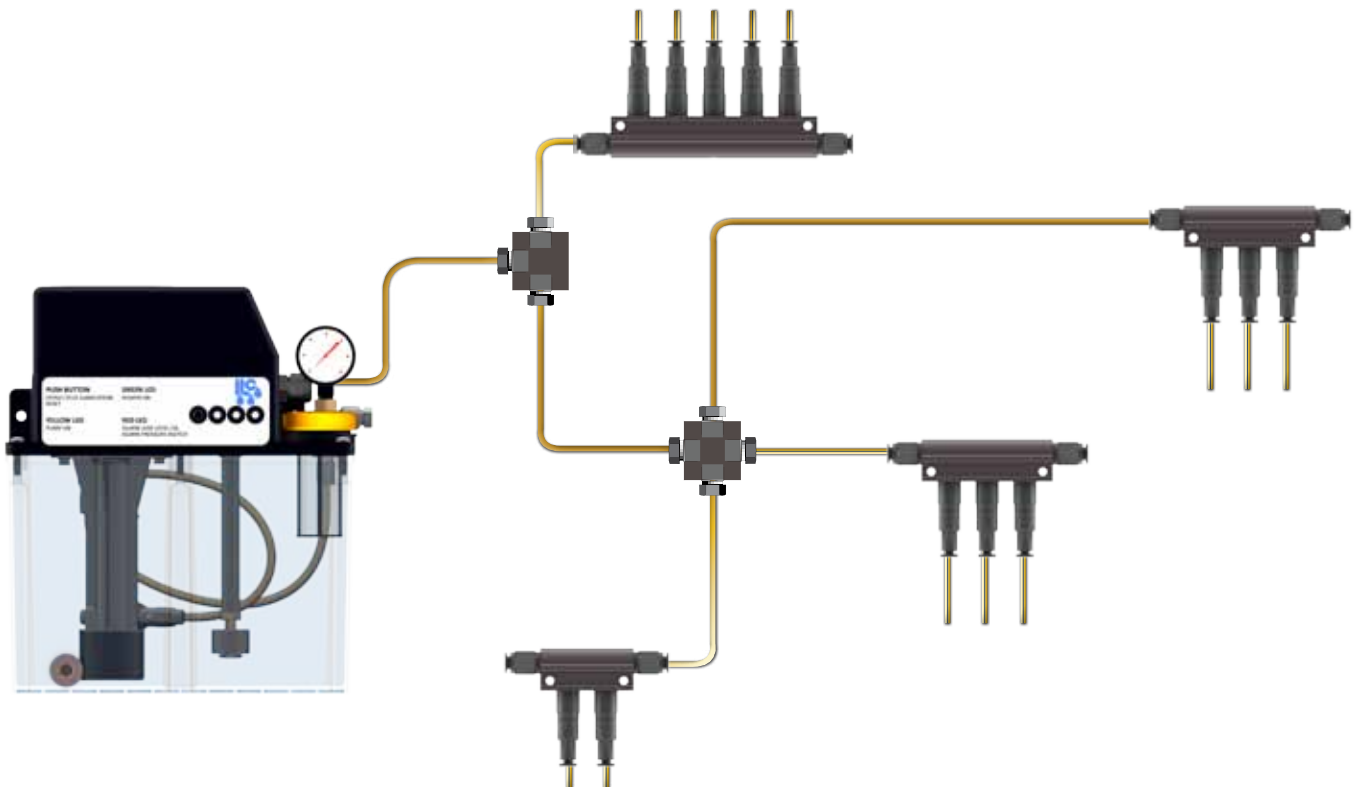

L'aspetto dei prodotti illustrati è puramente indicativo e non rappresenta il prodotto finale.

MANIFOLDS

SINGLE-JUNCTION MANIFOLDS M12x1-M10x1

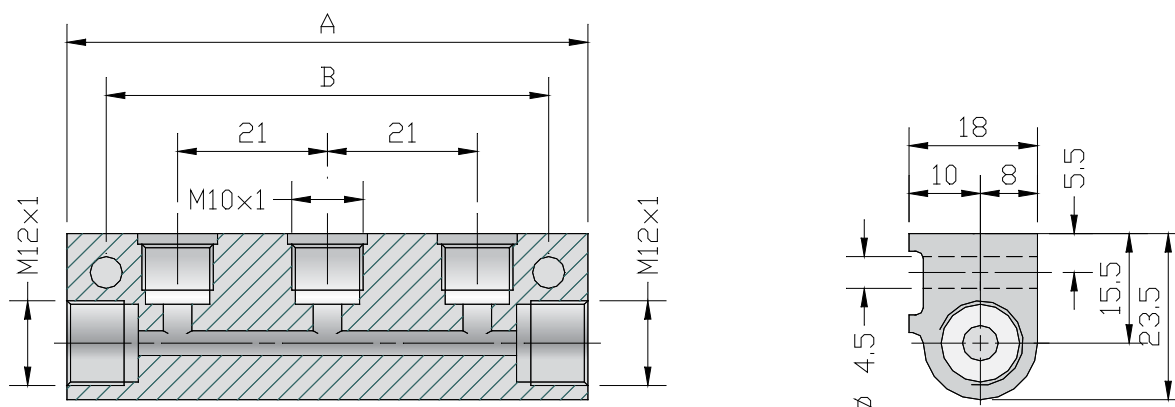

DOUBLE-JUNCTION MANIFOLDS M12x1-M10x1

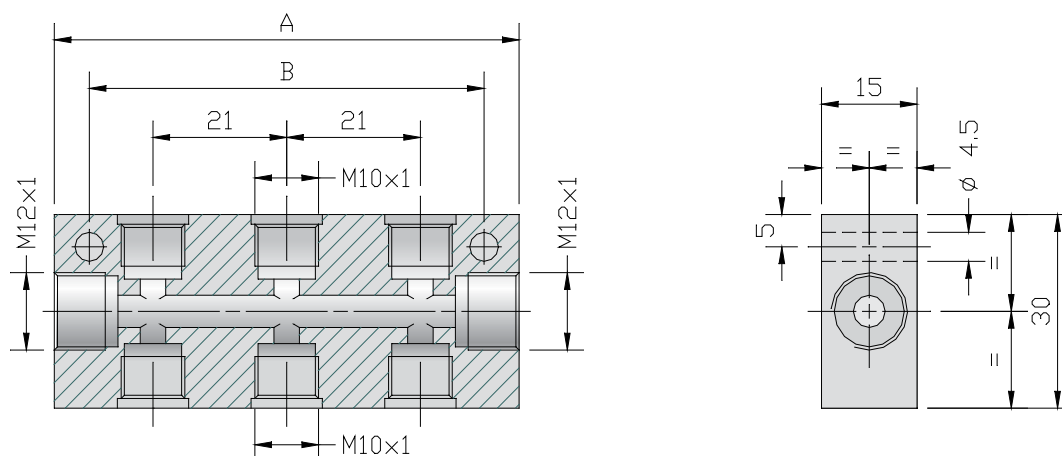

SINGLE-JUNCTION MANIFOLDS

CODE	OUTLETS	A	B
01.520.0	1	31	20
01.521.0	2	52	41
01.522.0	3	73	62
01.523.0	4	94	83
01.524.0	5	115	104
01.525.0	6	136	125
01.526.0	7	157	146
01.527.0	8	178	167
01.528.0	9	199	188
01.529.0	10	220	209

DOUBLE-JUNCTION MANIFOLDS

CODE	OUTLETS	A	B
01.540.0	2	31	20
01.541.0	4	52	41
01.542.0	6	73	62
01.543.0	8	94	83
01.544.0	10	115	104
01.545.0	12	136	125
01.546.0	14	157	146

FIXING MALE SCREWS M4x25
CODE 15.031.0

OUTLET FITTINGS FOR METERING VALVES



M10x1 (M) – M10x1 (M)

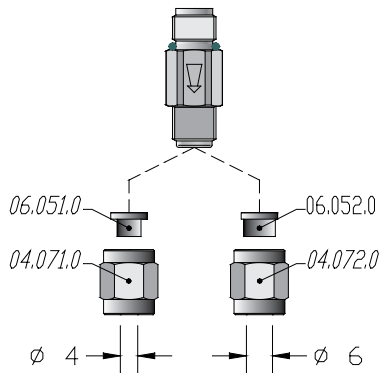

M10x1 (M) – M8x1 (F)

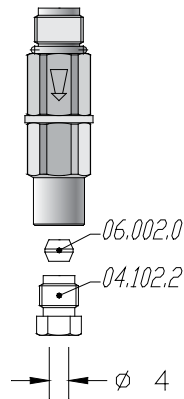

PUSH- IN

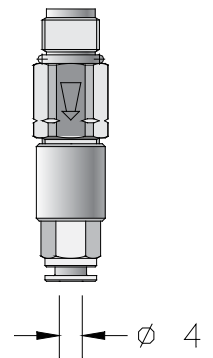

MANIFOLD M12x1-M10x1 FITTINGS

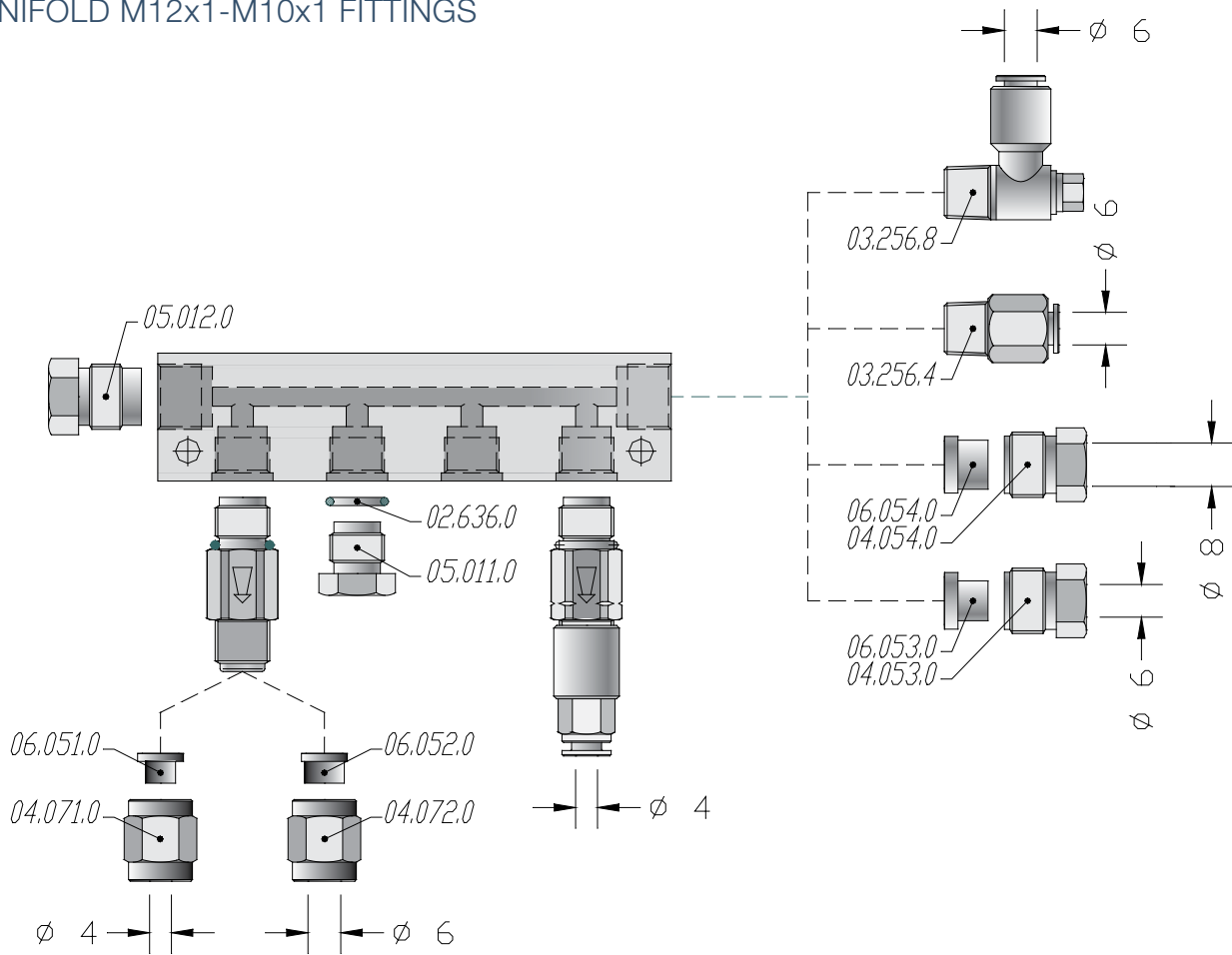

L'aspetto dei prodotti può essere soggetto a modifica senza preavviso.

MANIFOLDS

SINGLE-JUNCTION MANIFOLDS M10x1-M10x1 2 WAYS

CODE 01.961.0

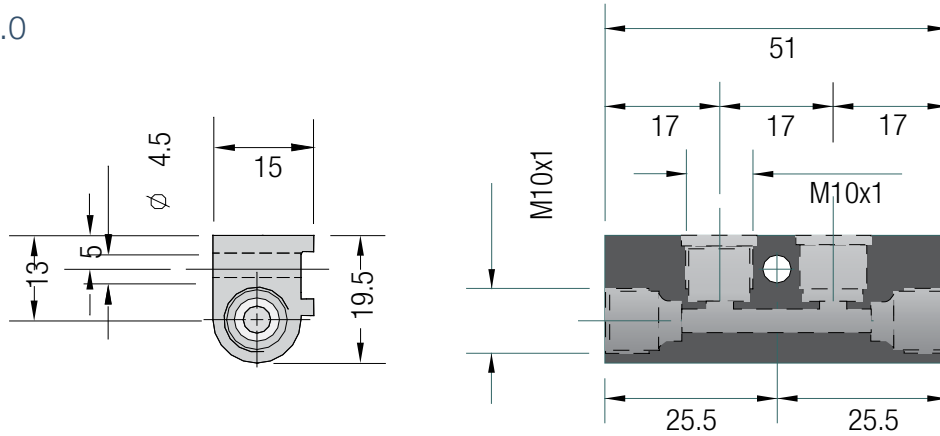

SINGLE-JUNCTION MANIFOLDS M10x1-M10x1 3 WAYS

CODE 01.961.1

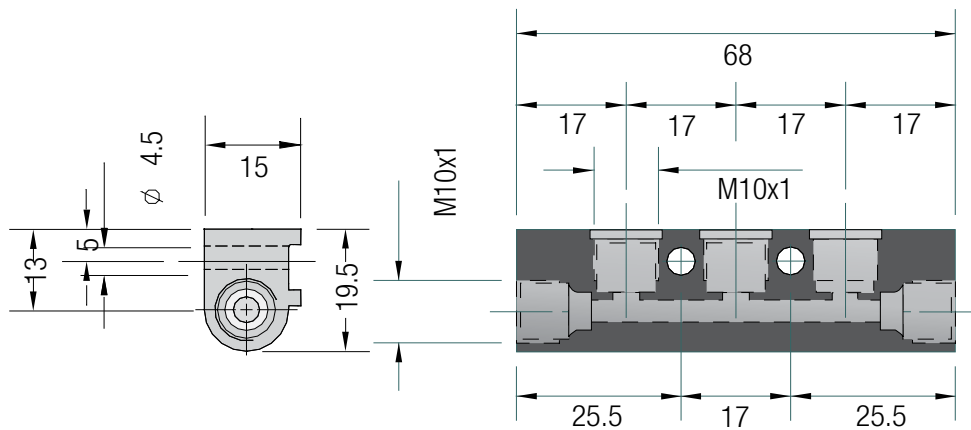

SINGLE-JUNCTION MANIFOLDS M10x1-M10x1 5 WAYS

CODE 01.961.2

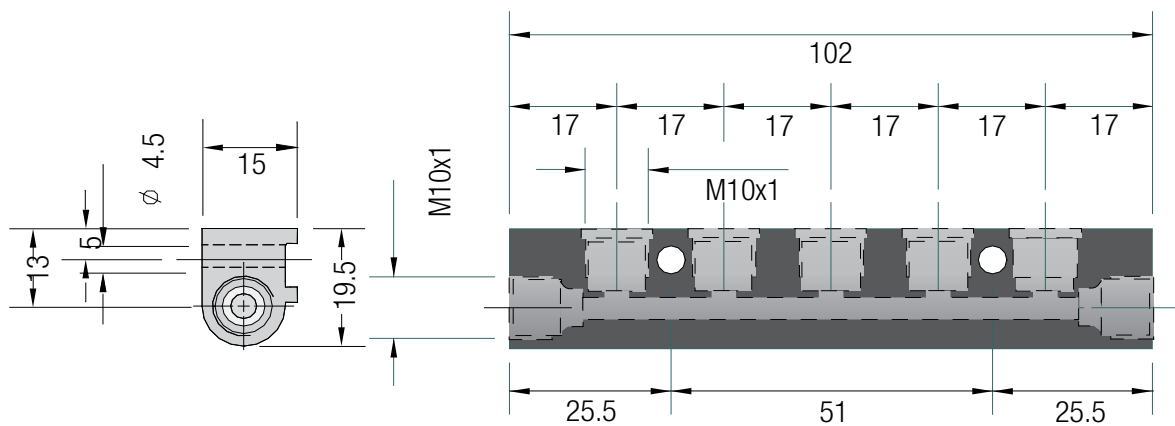

MANIFOLD M10x1-M10x1 FITTINGS

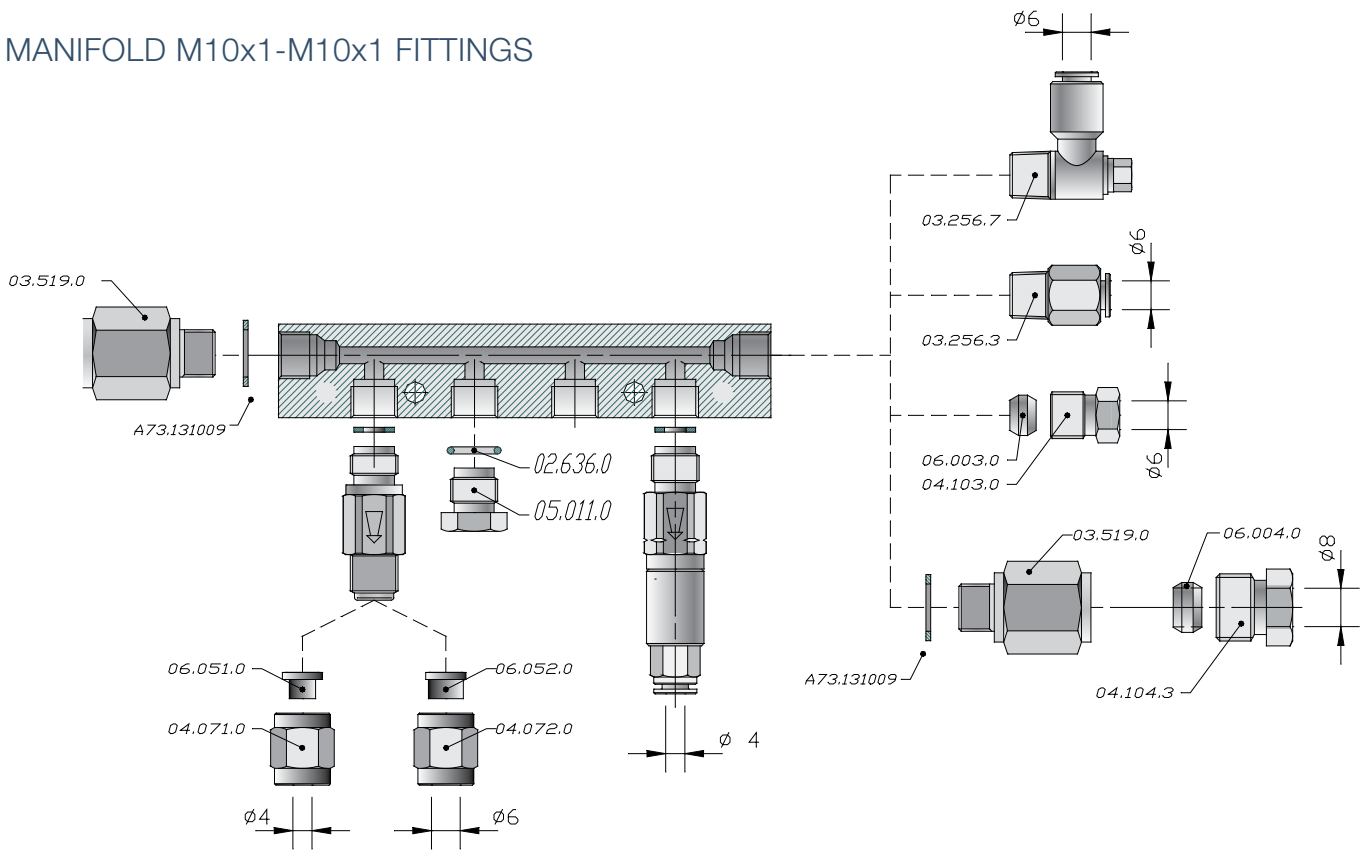

L'aspetto dei prodotti non rappresenta l'aspetto reale e non è garantito senza preavviso.

METERING VALVES 1/8" (M) – M10x1 (M) FOR MANIFOLD

THE SEALS ARE IN NBR. ON REQUEST IS POSSIBLE TO SUPPLY THE VALVES WITH VITON SEALS. HAVE TO BE ADD .V TO THE CODE

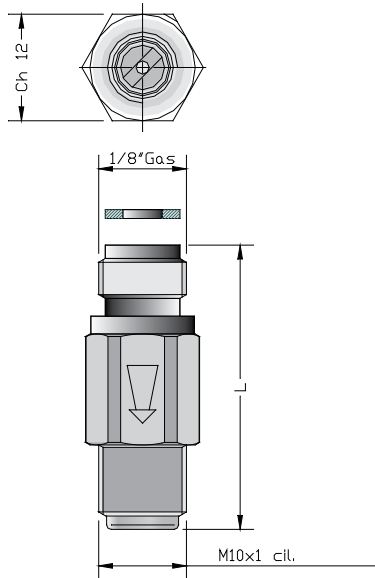

CODE	MARKING	METERED Q.TY	L
02.739.0	15	15 MM ³	32 MM
02.739.1	30	30 MM ³	32 MM
02.739.2	60	60 MM ³	32 MM
02.739.3	100	100 MM ³	32 MM
02.739.4	160	160 MM ³	32 MM
02.739.5	200	200 MM ³	37.6 MM
02.739.6	300	300 MM ³	37.6 MM

METERING VALVES 1/8" (M) – PUSH IN FOR MANIFOLD

THE SEALS ARE IN NBR. ON REQUEST IS POSSIBLE TO SUPPLY THE VALVES WITH VITON SEALS. HAVE TO BE ADD .V TO THE CODE

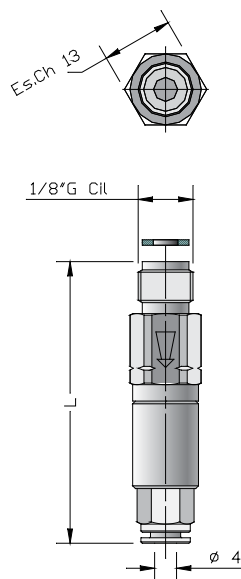

CODE	MARKING	METERED Q.TY	L
02.742.0	15	15 MM ³	51 MM
02.742.1	30	30 MM ³	51 MM
02.742.2	60	60 MM ³	51 MM
02.742.3	100	100 MM ³	51 MM
02.742.4	160	160 MM ³	51 MM
02.742.5	200	200 MM ³	56.6 MM
02.742.6	300	300 MM ³	56.6 MM

METERING VALVES 1/8" (M) – 5/16 (M) FOR MANIFOLD

THE SEALS ARE IN NBR. ON REQUEST IS POSSIBLE TO SUPPLY THE VALVES WITH VITON SEALS. TO BE ADD .V TO THE CODE



CODE	MARKING	METERED Q.TY	L
02.737.0	15	15 MM ³	42 MM
02.737.1	30	30 MM ³	42 MM
02.737.2	60	60 MM ³	42 MM
02.737.3	100	100 MM ³	42 MM
02.737.4	160	160 MM ³	42 MM
02.737.5	200	200 MM ³	47.6 MM
02.737.6	300	300 MM ³	47.6 MM

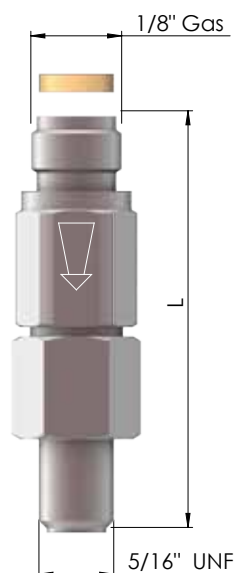

MANIFOLDS

SINGLE-JUNCTION MANIFOLDS 1/8" - 1/8"

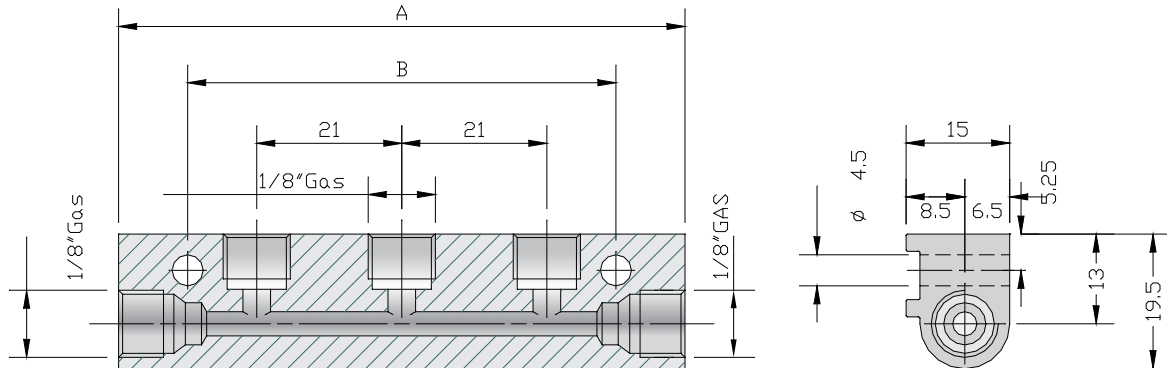

DOUBLE-JUNCTION MANIFOLDS 1/8" - 1/8"

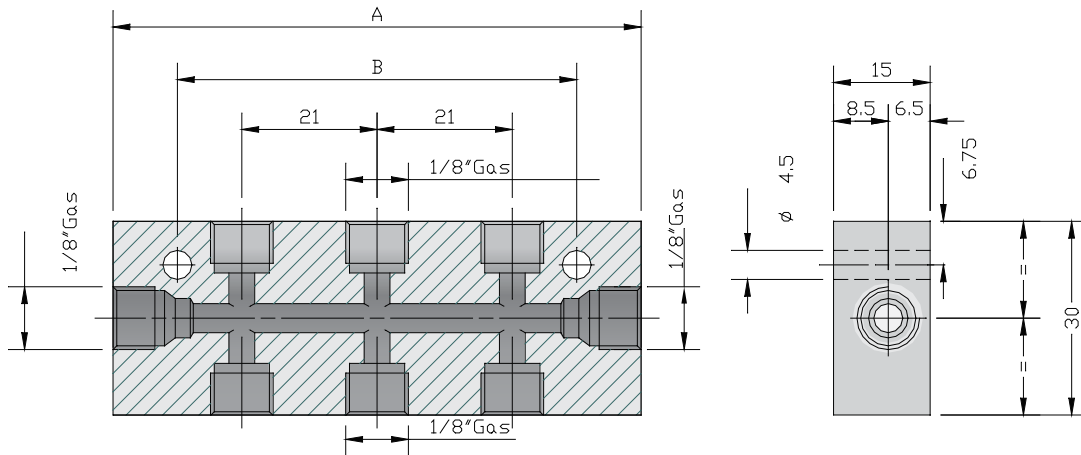

SINGLE-JUNCTION MANIFOLDS

CODE	OUTLETS	A	B
01.420.0	1	40	20
01.420.1	2	61	41
01.420.2	3	82	62
01.420.3	4	103	83
01.420.4	5	124	104
01.420.5	6	145	125
01.420.6	7	166	146
01.420.7	8	187	167
01.420.8	9	208	188
01.420.9	10	229	209

DOUBLE-JUNCTION MANIFOLDS

CODE	OUTLETS	A	B
01.421.0	2	40	20
01.421.1	4	61	41
01.421.2	6	82	62
01.421.3	8	103	83
01.421.4	10	124	104
01.421.5	12	145	125
01.421.6	14	166	146

FIXING MALE SCREWS M4x25
CODE 15.031.0

L'aspetto e le dimensioni tecniche possono essere modificate senza preavviso.

OUTLET FITTINGS FOR METERING VALVES

1/8" (M) – M10x1 (M)

1/8" (M) – 5/16" (F)

1/8" – PUSH IN

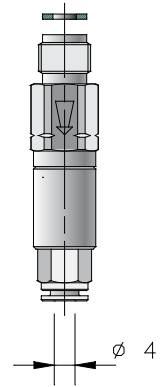
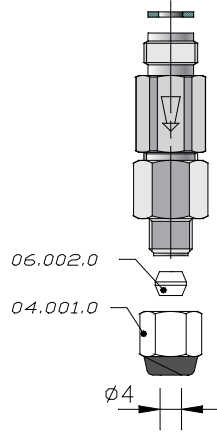
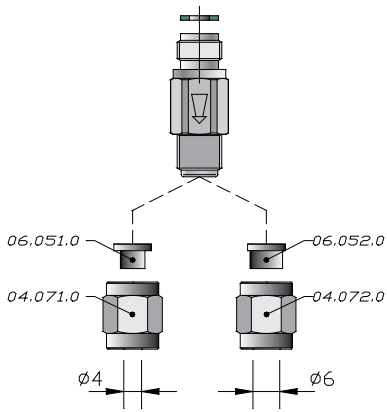

MANIFOLD 1/8" – 1/8" FITTINGS

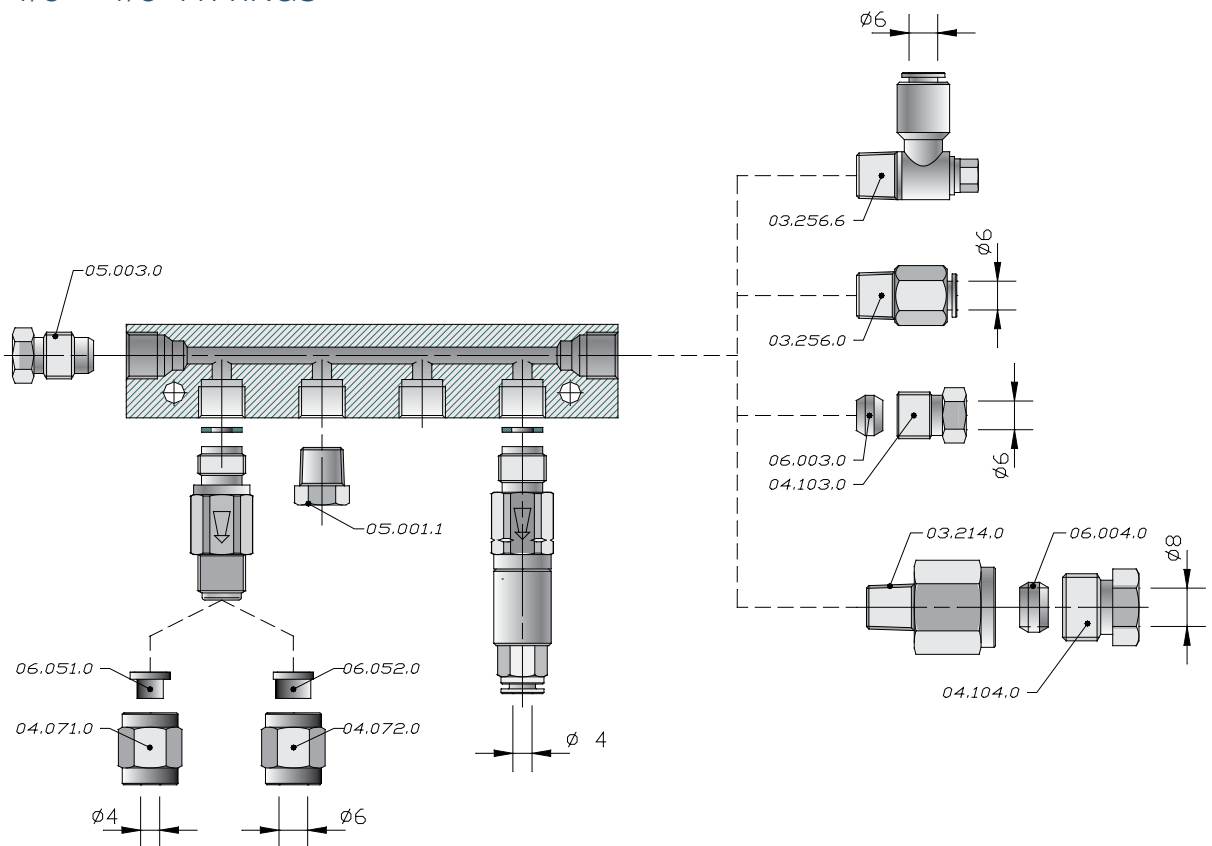

L'aspetto dei prodotti può essere soggetto a modifica senza preavviso

STRAIGHT METERING VALVES M10x1 (M) – 1/4" (M) FOR POINT

STRAIGHT METERING VALVES M10x1 (M) – 1/4" (M) FOR POINT

THE SEALS ARE IN NBR. ON REQUEST IS POSSIBLE TO SUPPLY THE VALVES WITH VITON SEALS. HAVE TO BE ADD .V TO THE CODE

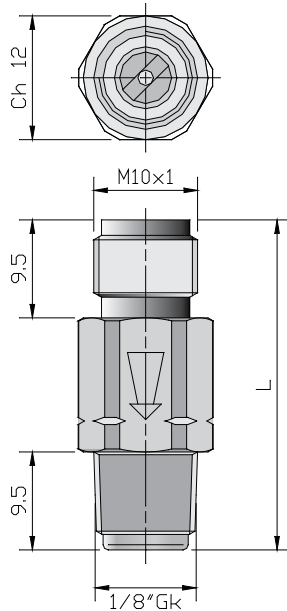

CODICE	MARCATURA	DOSAGGIO	L
02.711.0	15	15 MM ³	32 MM
02.711.1	30	30 MM ³	32 MM
02.711.2	60	60 MM ³	32 MM
02.711.3	100	100 MM ³	32 MM
02.711.4	160	160 MM ³	32 MM
02.711.5	200	200 MM ³	37.6 MM
02.711.6	300	300 MM ³	37.6 MM

STRAIGHT METERING VALVES 5/16" (M) – 1/8" (M) FOR POINT

THE SEALS ARE IN NBR. ON REQUEST IS POSSIBLE TO SUPPLY THE VALVES WITH VITON SEALS. HAVE TO BE ADD .V TO THE CODE

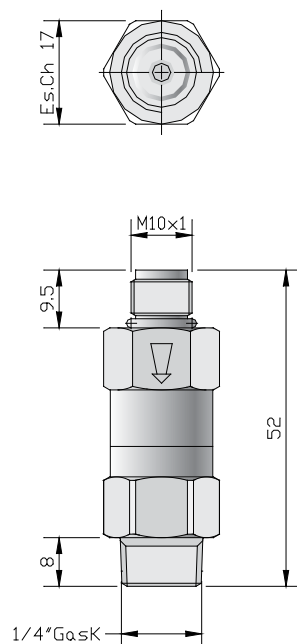

CODICE	MARCATURA	DOSAGGIO
02.602.6	6	500 MM ³
02.602.7	7	750 MM ³
02.602.8	8	1000 MM ³

L'aspetto dei prodotti può essere soggetto a modifiche senza preavviso

VALVOLE PER PUNTO PUSH-IN TUBO 4 MM – 1/8" (M) DIRITTO

STRAIGHT METERING VALVES PUSH IN – 1/8" (M) FOR POINT
THE SEALS ARE IN NBR. ON REQUEST IS POSSIBLE TO SUPPLY THE VALVES WITH VITON SEALS. HAVE TO BE ADD .V TO THE CODE

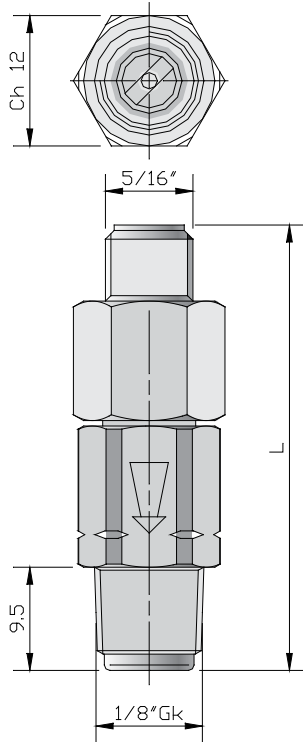

CODICE	MARCATURA	DOSAGGIO	L
02.736.0	15	15 MM ³	41 MM
02.736.1	30	30 MM ³	41 MM
02.736.2	60	60 MM ³	41 MM
02.736.3	100	100 MM ³	41 MM
02.736.4	160	160 MM ³	41 MM
02.736.5	200	200 MM ³	46.6 MM
02.736.6	300	300 MM ³	46.6 MM

STRAIGHT METERING VALVES M10x1 (M) – 1/8" (M) FOR POINT
THE SEALS ARE IN NBR. ON REQUEST IS POSSIBLE TO SUPPLY THE VALVES WITH VITON SEALS. HAVE TO BE ADD .V TO THE CODE

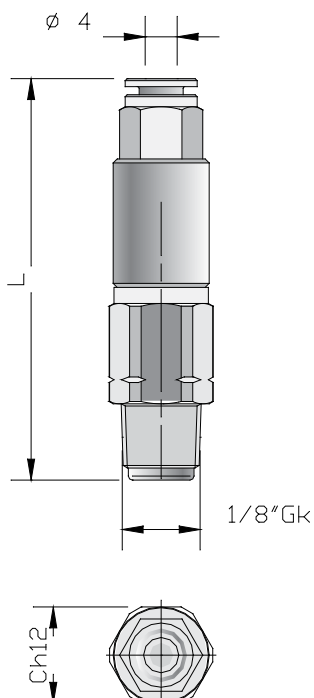

CODICE	MARCATURA	DOSAGGIO	L
02.712.0	15	15 MM ³	46.5 MM
02.712.1	30	30 MM ³	46.5 MM
02.712.2	60	60 MM ³	46.5 MM
02.712.3	100	100 MM ³	46.5 MM
02.712.4	160	160 MM ³	46.5 MM
02.712.5	200	200 MM ³	52.1 MM
02.712.6	300	300 MM ³	52.1 MM

FITTINGS

INLET FITTINGS FOR METERING VALVES

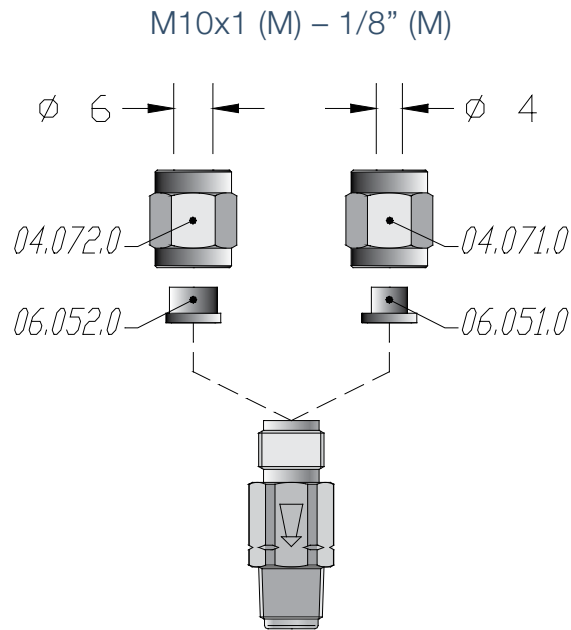

MANIFOLD FITTINGS

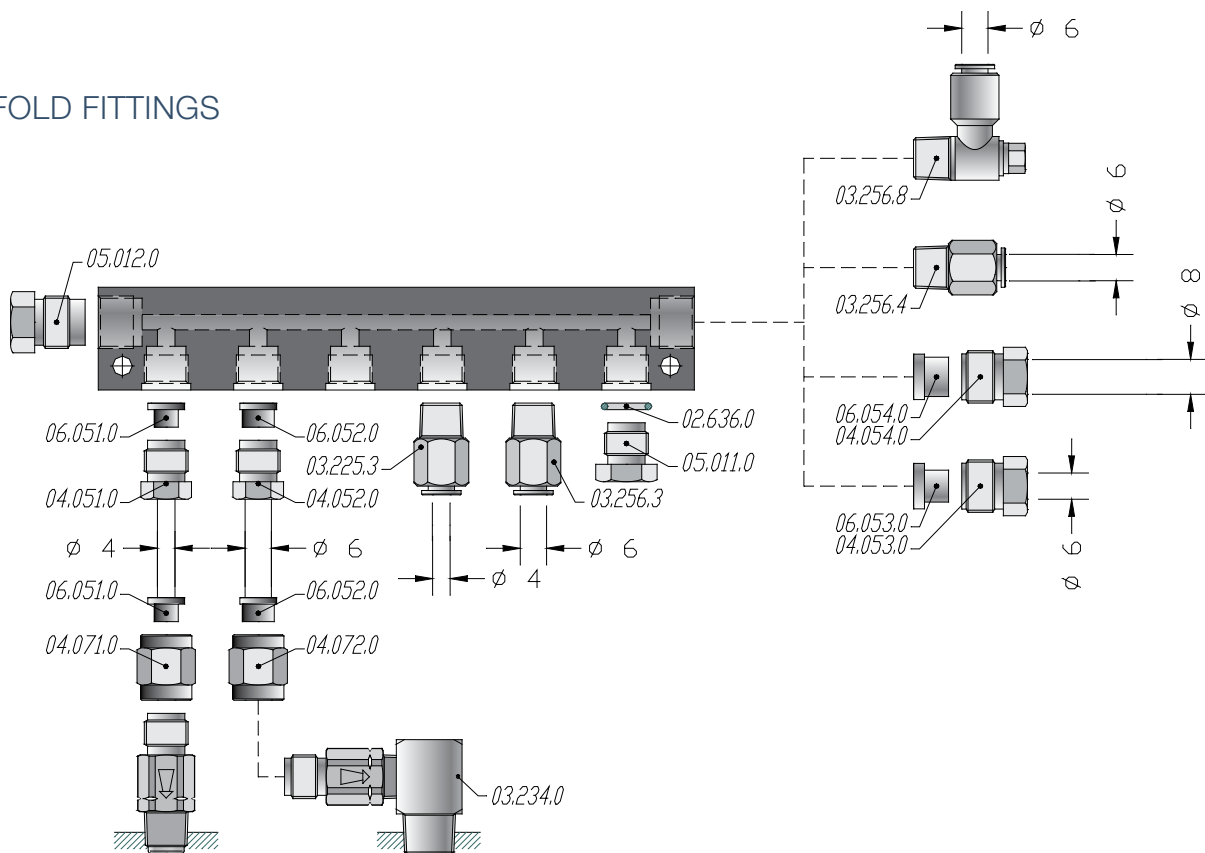

L'aspetto dei prodotti può essere soggetto a modifica senza preavviso

OUTLET FITTINGS FOR METERING VALVES

09.015.0

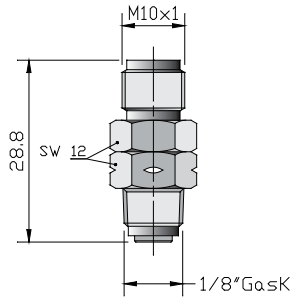

09.016.0

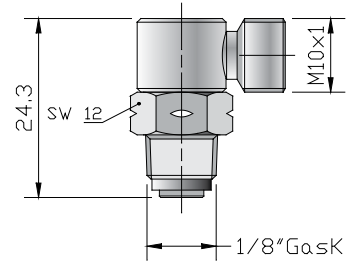

09.018.0

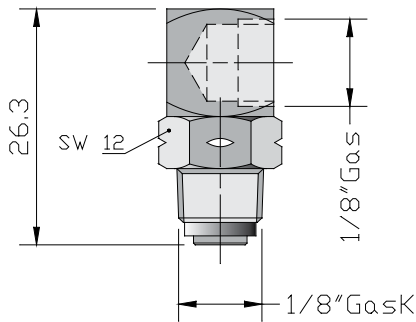

09.020.0

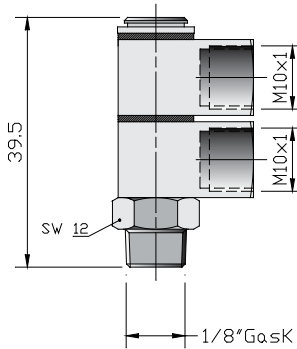

09.023.4

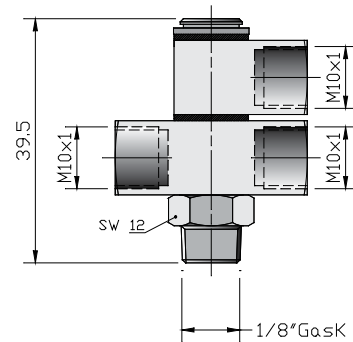

09.023.6

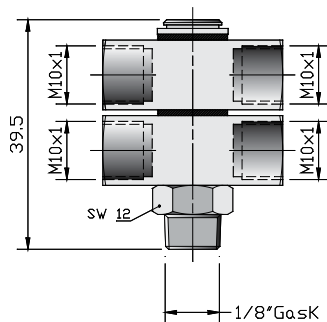

Lubrificazione e lubrificanti per prodotti agricoli

FITTINGS

ROTATING JOINT FITTINGS

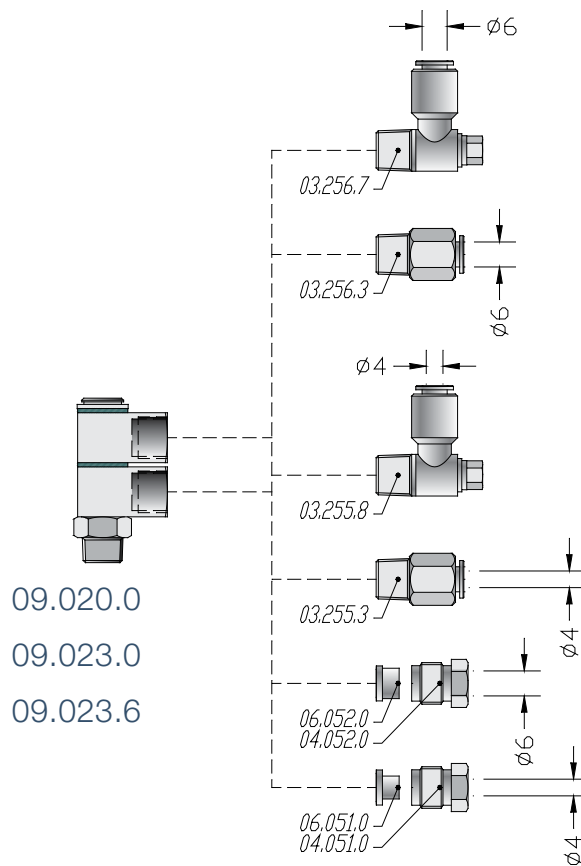
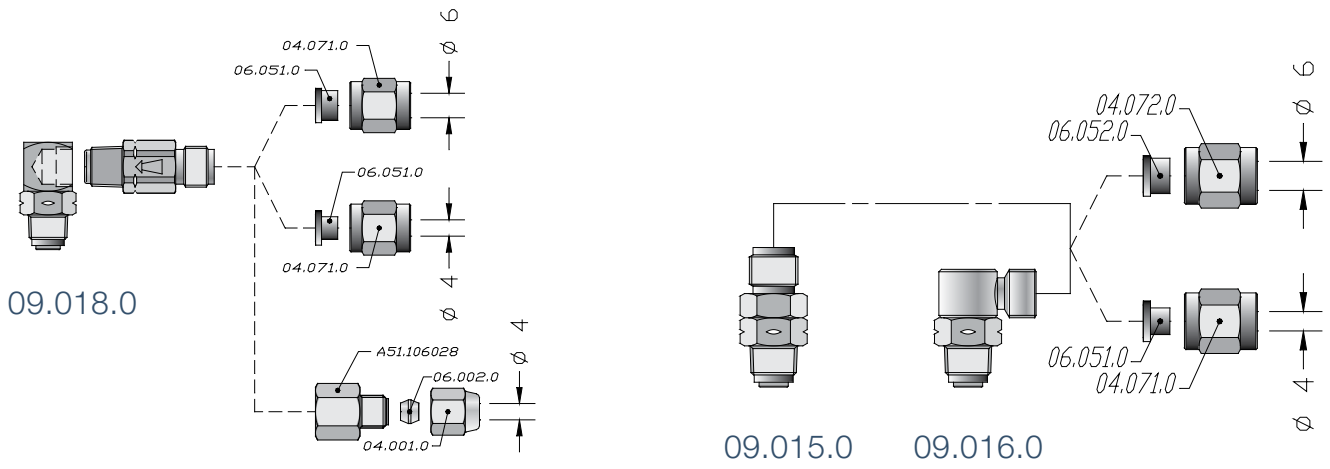

L'aspetto dei prodotti può essere soggetto a modifiche senza preavviso

Group 1 and group 2 Ilcomatic-3 metering valves

ILCOMATIC-3 piston distributors are suitable for “total loss” lubrication systems (oil or soft grease). They measure and distribute lubricant intermittently by means of a pump. Lubricant quantities for each point can be easily changed in the event new discharge. The supply of the total lubricant requirement can be further controlled by the lubrication frequency. These piston distributors are preassembled with aluminium manifolds with a definite number of outlets. It can be supplied single piston distributor to assemble to appropriate manifolds. During the lubrication system planning it is necessary to prearrange a metering valve for each point, calculate to the total lubricant quantity and choose the right pump.

Time interval between a cycle and another: 20 seconds.

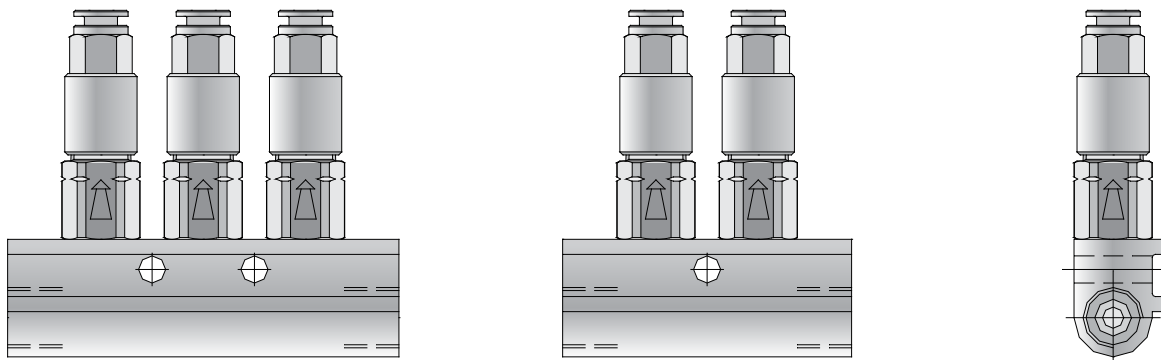

METERING VALVES ILCOMATIC-3
ILCOMATIC-3 METERING VALVES GROUP 1
Codes To Order

GROUP 1 CODES			
CODE	OUTLETS	A	B
352/	2	51	//
353/	3	68	17
355/	5	102	51

VALVE CODES		
CODE	MARKING	METERED Q.TY
02.713.0	15 MM ³	15
02.713.1	30 MM ³	30
02.713.2	60 MM ³	60
02.713.3	100 MM ³	100
02.713.4	160 MM ³	160
02.713.5	200 MM ³	200
02.713.6	300 MM ³	300

HOW TO ORDER

THE REFERENCE NUMBER HAS TO BE COMPLETED BY ADDING THE MARKING NUMBER OF THE VALVE

EXAMPLE

PISTON DISTRIBUTOR 5 OUTLETS

BASIC CODE 355/

REQUESTED DISCHARGE FROM LEFT TO RIGHT 100 – 0 – 160 – 30 - 60

MARKING NUMBERS 100-0-160-30-60

COMPLETE CODE 355/100-X-160-30-60

X MEANS DISCHARGE=0. THE OUTLET WILL BE SUPPLIED WITH A M10x1 PLUG.

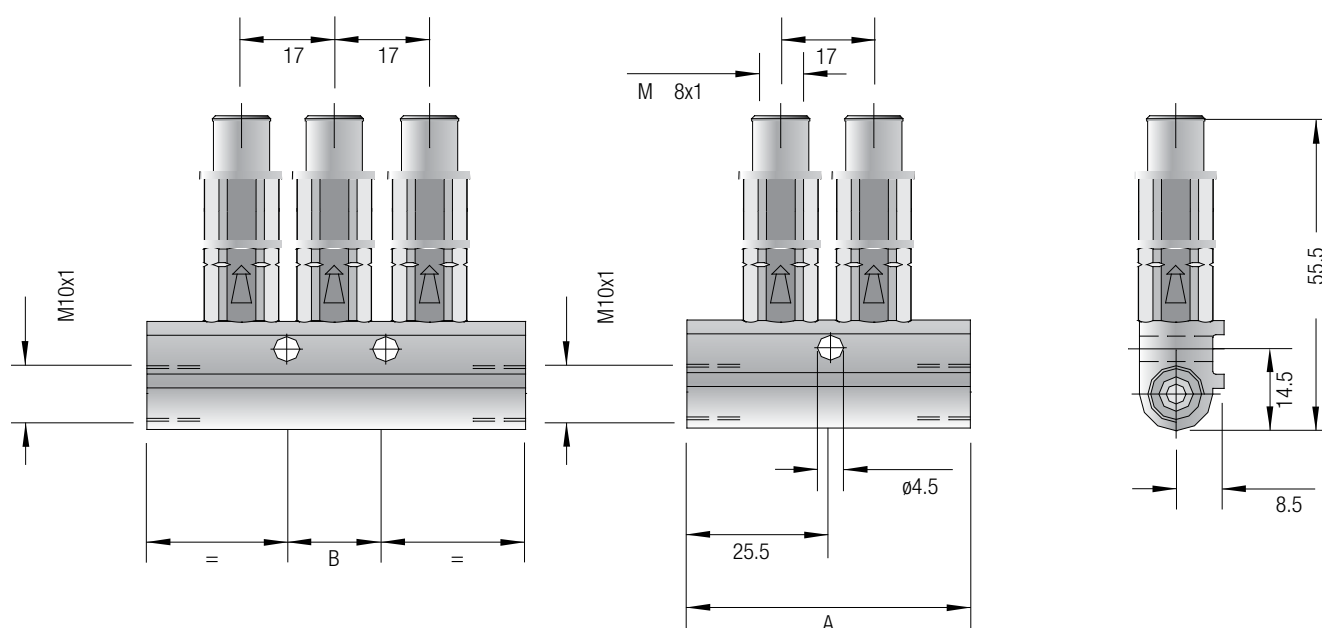

ADAPTOR TO JOIN M10x1-M10X1 MANIFOLDS
CODE 03.000.1

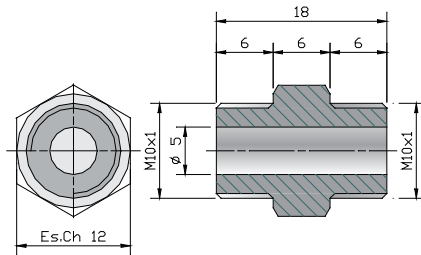

GROUP 1 ILCOMATIC-3
METERING VALVE FITTINGS

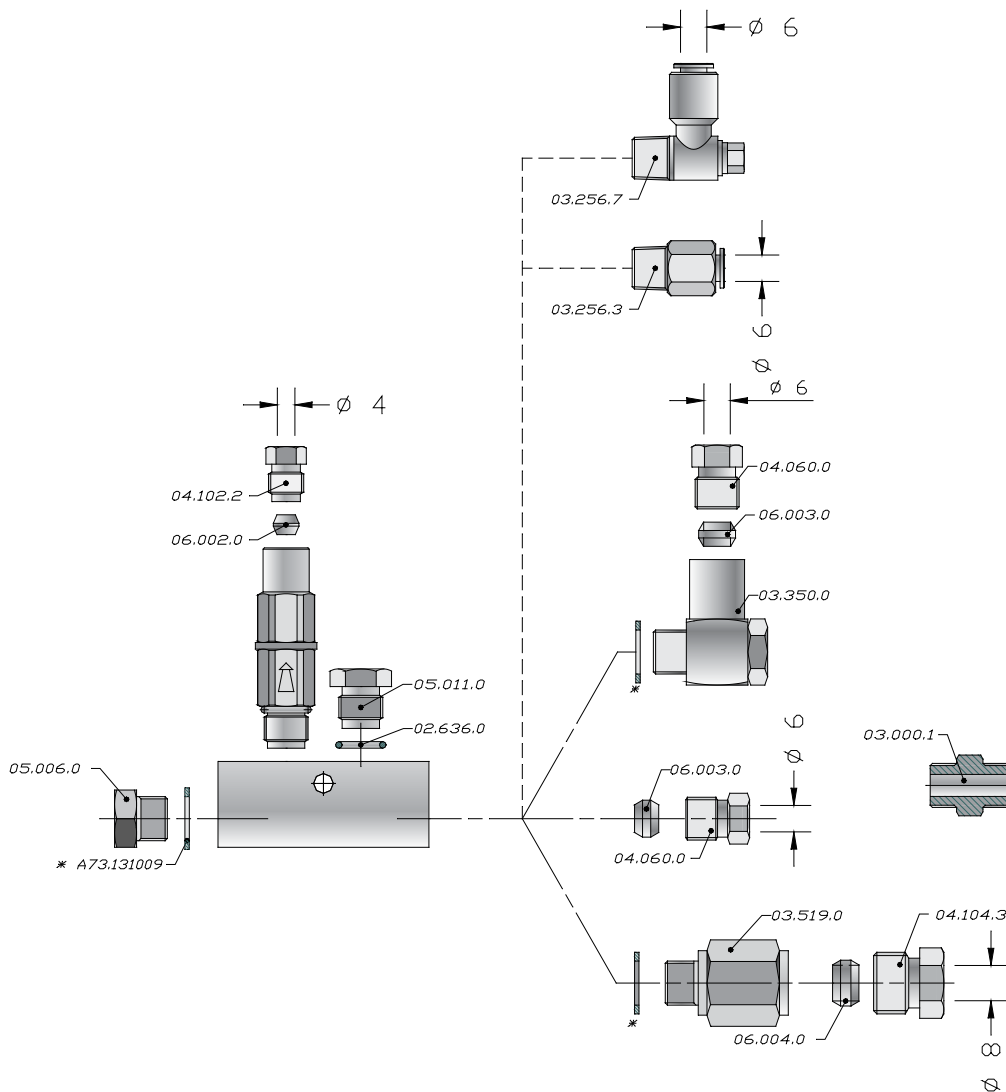

L'aspetto dei prodotti può essere soggetto a modifica senza preavviso

ILCOMATIC-3 METERING VALVES

GROUP 1 PUSH-IN ILCOMATIC-3 METERING VALVES

Codes to Order

GROUP 1 CODES			
CODE	OUTLETS	A	B
352PI/	2	51	//
353PI/	3	68	17
355PI/	5	102	51

VALVES CODE		
CODE	MARKING	METERED Q.TY
02.710.0	15 MM ³	15
02.710.1	30 MM ³	30
02.710.2	60 MM ³	60
02.710.3	100 MM ³	100
02.710.4	160 MM ³	160
02.710.5	200 MM ³	200
02.710.6	300 MM ³	300

HOW TO ORDER

THE REFERENCE NUMBER HAS TO BE COMPLETED BY ADDING THE MARKING NUMBER OF THE VALVE

EXAMPLE

PISTON DISTRIBUTOR 5 OUTLETS

BASIC CODE 355/

REQUESTED DISCHARGE FROM LEFT TO RIGHT 100 – 0 – 160 – 30 - 60

MARKING NUMBERS 100-0-160-30-60

COMPLETE CODE 355/100-X-160-30-60

X MEANS DISCHARGE=0. THE OUTLET WILL BE SUPPLIED WITH A M10x1 PLUG.

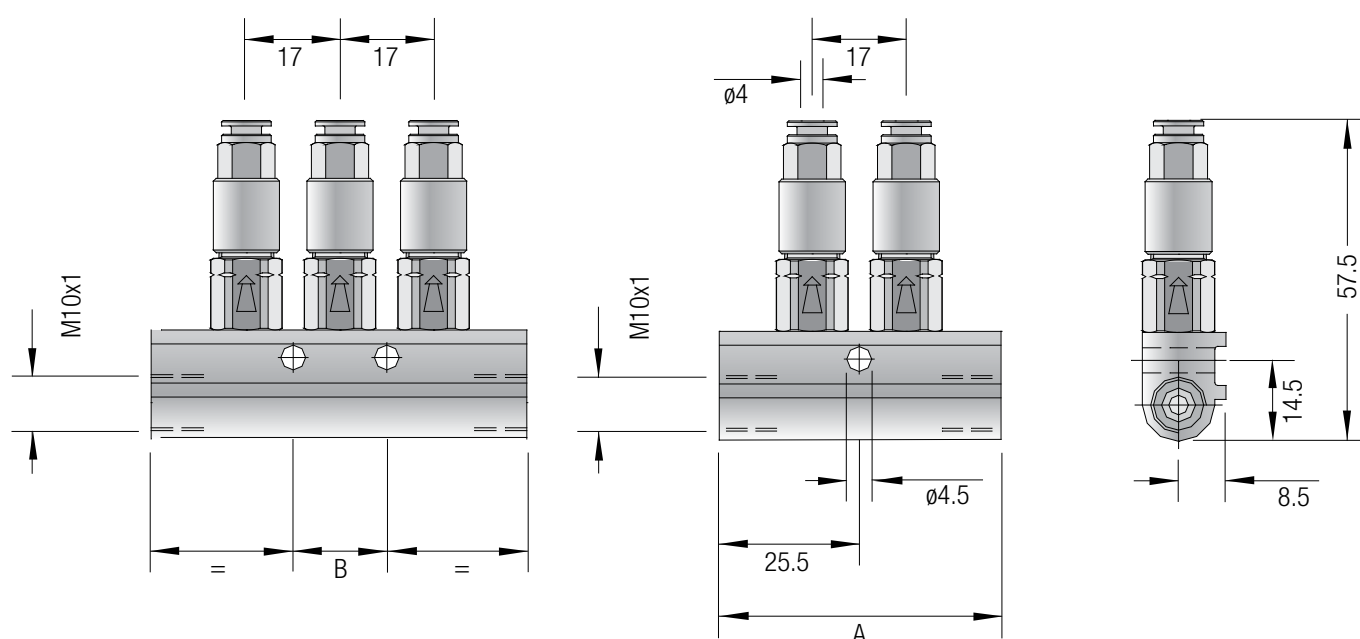

ADAPTOR TO JOIN M10x1-M10X1 MANIFOLDS
CODE 03.000.1

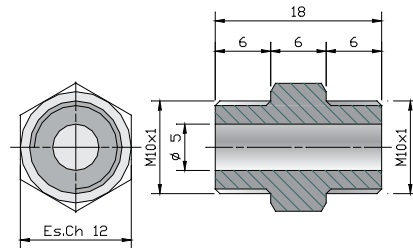

GROUP 1 PUSH-IN ILCOMATIC-3
METERING VALVE FITTINGS

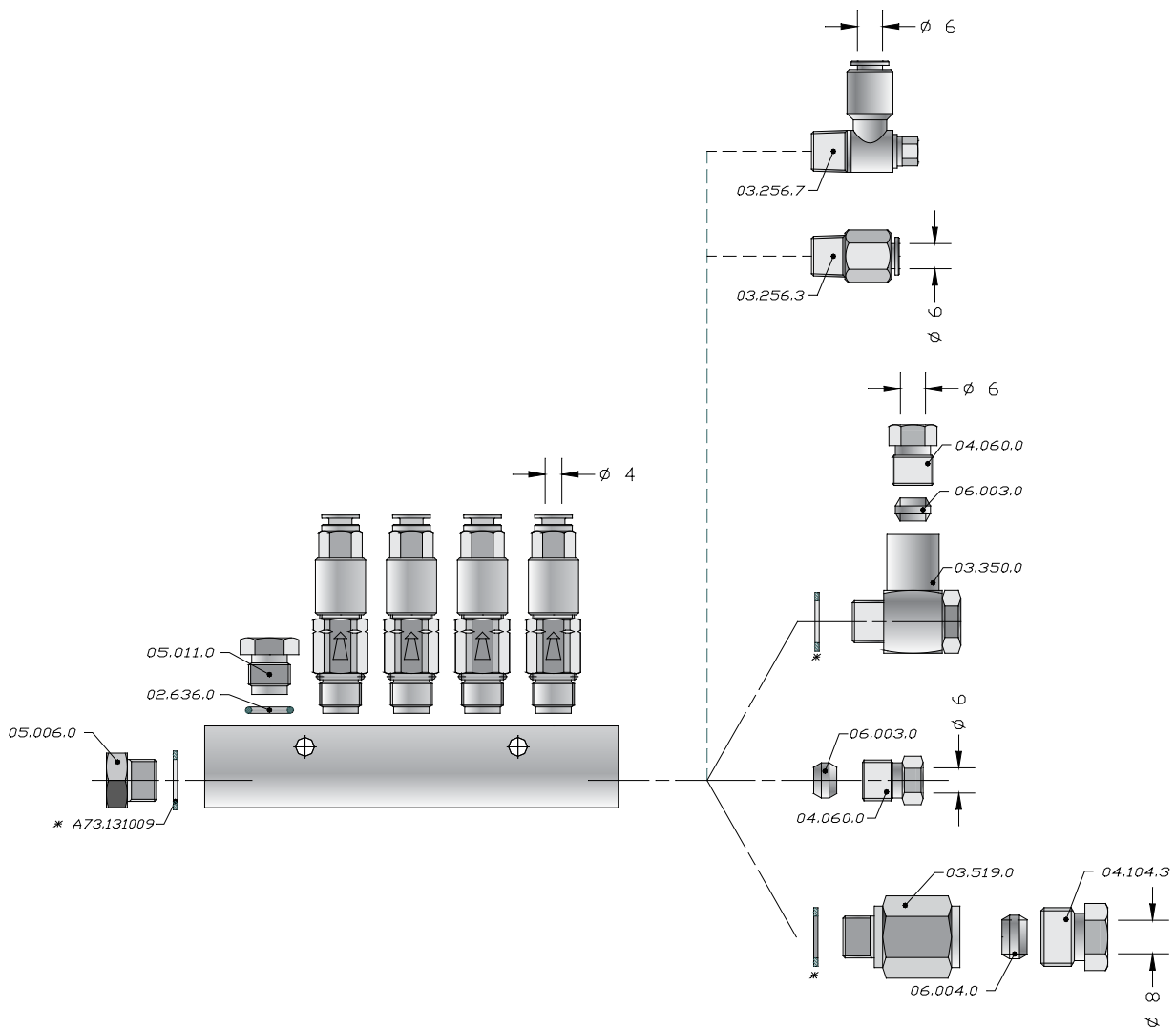

L'aspetto dei prodotti può essere soggetto a modifica senza preavviso

ILCOMATIC-3 METERING VALVE

GROUP 2 ILCOMATIC-3 METERING VALVE

The Reference Number Has To Be Completed By Adding The Order Code Of Metering Nipples
EXAMPLE

PISTON DISTRIBUTORS 5 OUTLETS

CODE = 35.050.6

REQUEST DISCHARGE

010 - 010 - 020 - 040 - 060

ORDER CODE

4 4 5 6 7

COMPLETE CODE =

35.050.6-44567

METERING NIPPLES CODE

CODE	OUTLETS	A
35.050.3	1	46
35.050.4	2	46
35.050.5	3	63
35.050.6	5	97

CODE	METERED Q.TY	ORDER CODE	MARKING
02.615.4	100 MM ³	4	01
02.615.5	200 MM ³	5	02
02.615.6	400 MM ³	6	04
02.615.7	600 MM ³	7	06

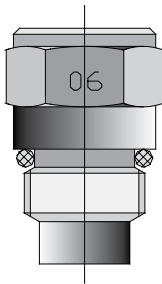

The ilcomatic-2 piston distributors are always supplied complete with metering nipples.

The metering nipples can be supplied separately complete with "o"-ring. The marking number is printed on the esagonal part.

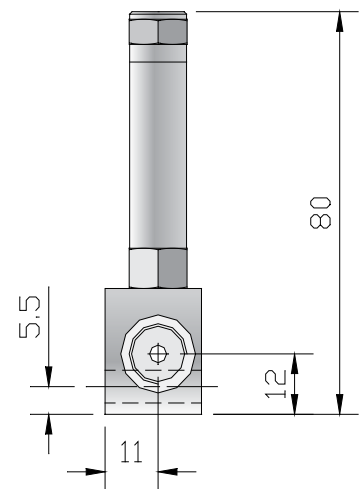
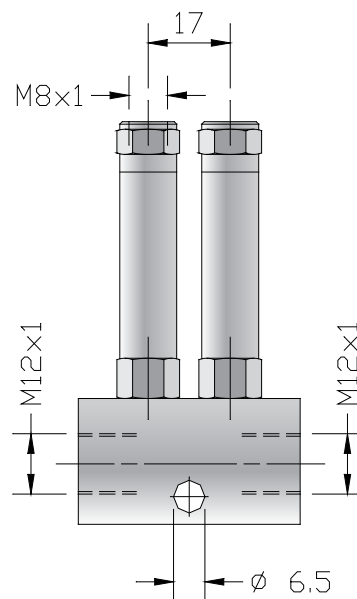
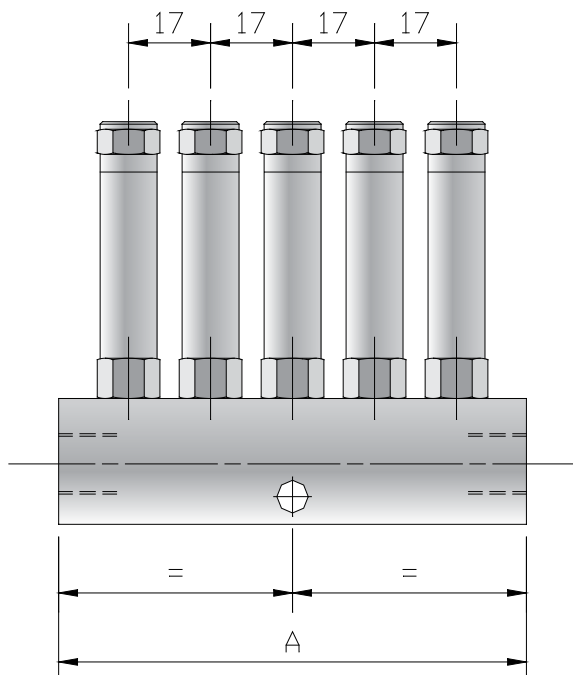

ADAPTOR TO JOIN M12x1-M10x1 MANIFOLDS
CODE 03.000.2

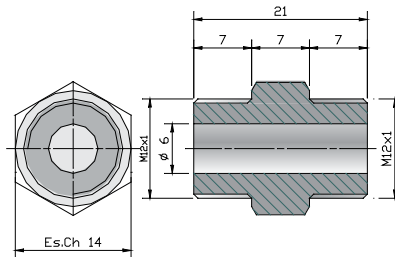

GROUP 2 ILCOMATIC-3
METERING VALVE FITTINGS

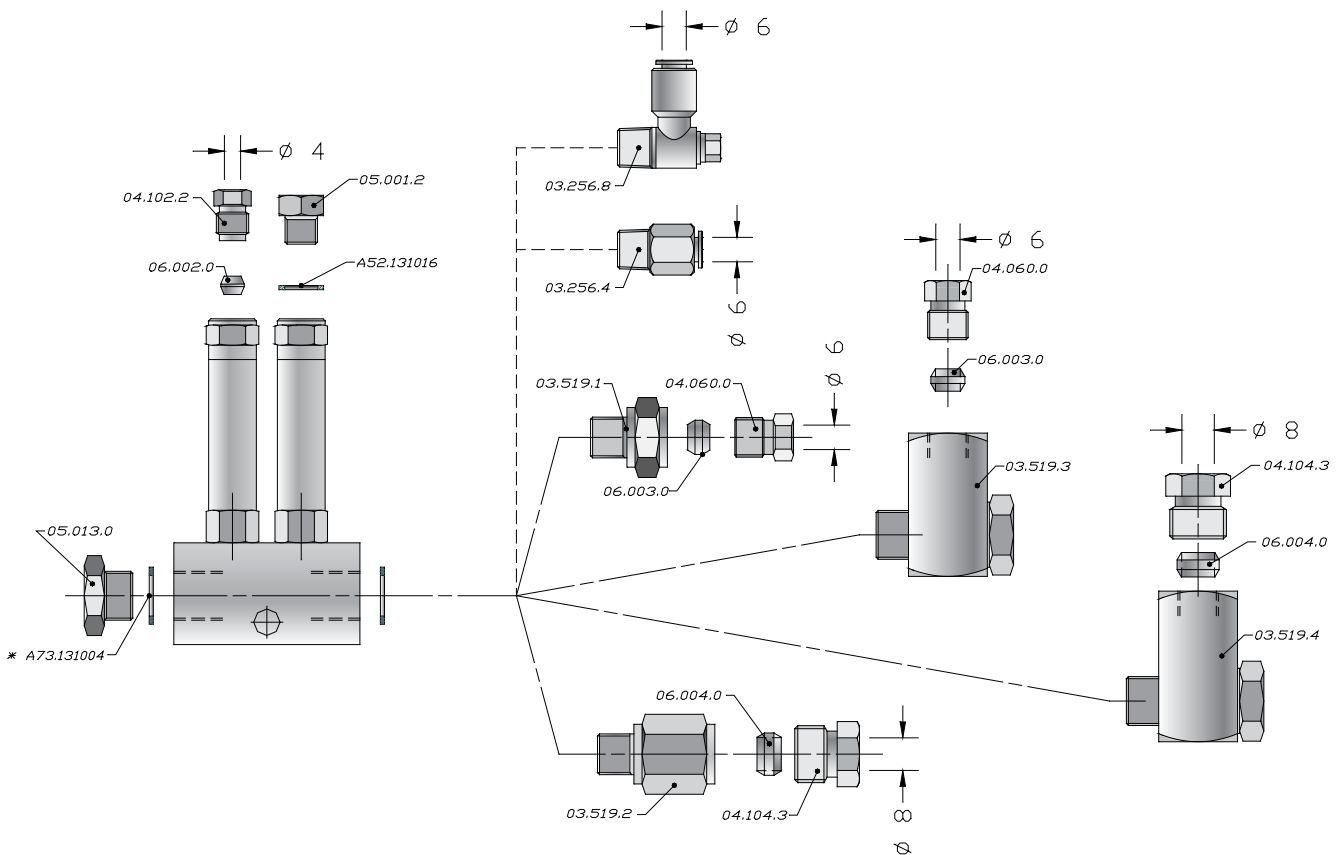

L'aspetto dei prodotti può essere soggetto a modifica senza preavviso

SINGLE PISTON METERING VALVES

SINGLE PISTON METERING VALVES GROUP 0

We can supply these single piston distributors to change a fault valve assembled in a manifold with outlets threaded m8x1.

On request it is possible to supply the manifolds too.

The single piston metering valves group 0 can not be assembled on the group 1 and 2

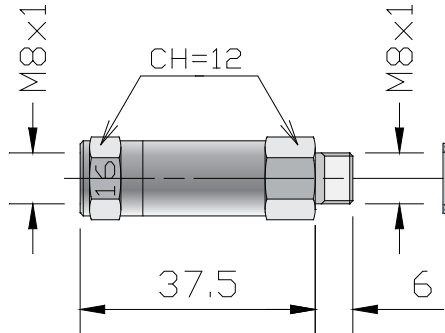

CODE	METERED Q.TY	MARKING
02.610.1	30 MM ³	3
02.610.2	60 MM ³	6
02.610.3	100 MM ³	10
02.610.4	160 MM ³	16

SINGLE PISTON METERING VALVES GROUP 4

We can supply these single piston distributors to change a fault valve assembled in a manifold with one outlet threaded m10x1.

The single piston metering valves group 4 can not be assembled on the group 1 and 2

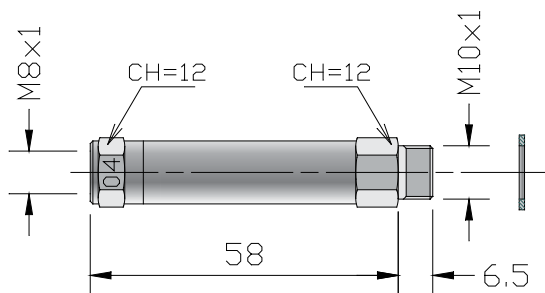

CODE	METERED Q.TY	MARKING
02.611.5	100 MM ³	01
02.611.6	200 MM ³	02
02.611.7	400 MM ³	04
02.611.8	600 MM ³	06

AIR+OIL MIXING VALVES MIXER-3

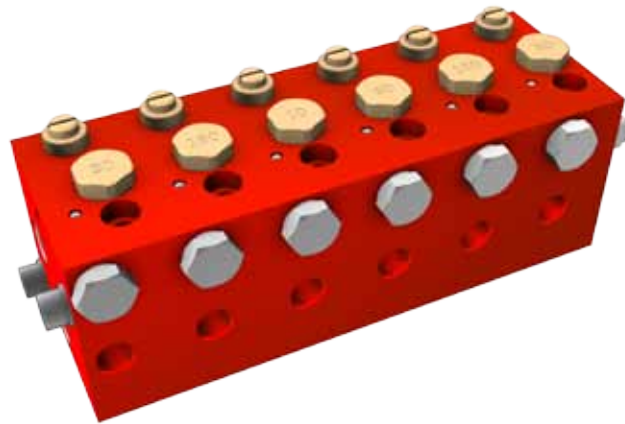

Mixers-3 embody a volumetric valve, available with different discharges. Air pressure is adjustable by mean of a screw with a clamping ferrule site up the mixer. Every outlet has her own discharge and elements can be assembled or be individually used. To feed the Mixer-3 is enough connect to the appropriate inlets air main line and oil main line.

Pump (electric or pneumatic) activates the Mixer-3 internal valve allowing the discharge of the preset oil quantity towards the mixing chamber. Airflow takes lubricant to the delivery area when the pump is working. Particles air-oil reaches lubrication points via tubes, conveyed by the air.

hydraulic layout with electric pump

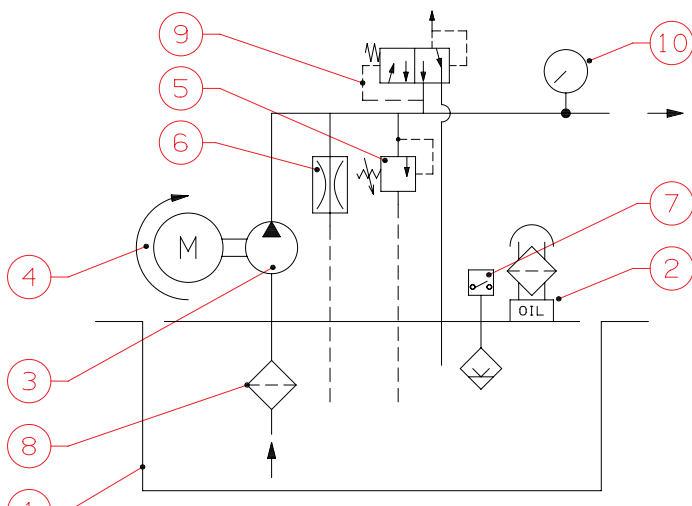

POS	NAME	POS	NAME
1	Reservoir	6	Valve trigger
2	Filler cap	7	Electrical Level
3	Gear pump	8	A filter of inspiration
4	electric Motor	9	Release valve
5	BY-PASS valve	10	Manometer

hydraulic layout with pneumatic pump

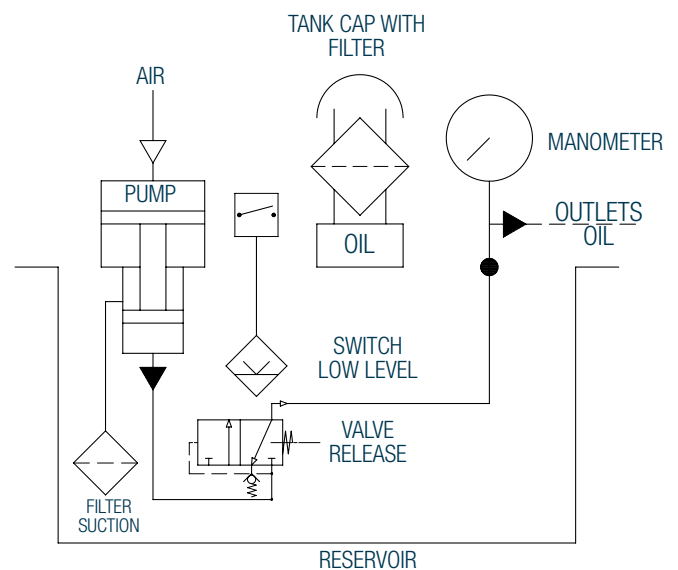

L'aspetto dei prodotti può essere soggetto a modifica senza preavviso

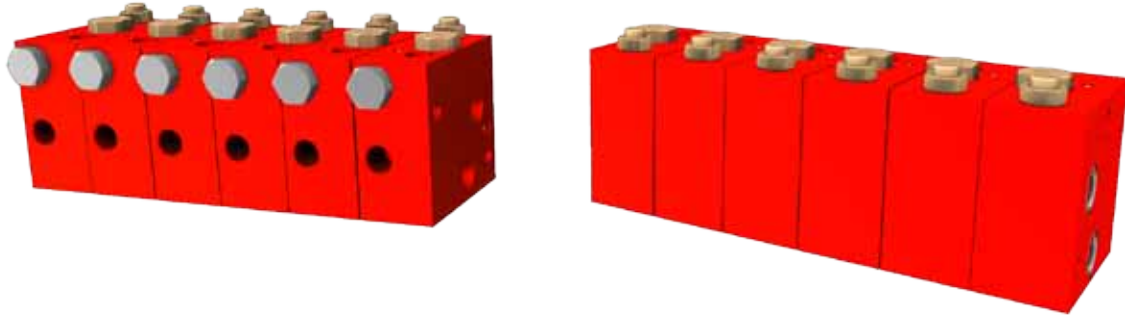
AIR+OIL MIXING VALVES MIXER-3
AIR+OIL MIXING VALVES MIXER-3

FEATURES	
AIR INLET	1/8"
OIL INLET	1/8"
AIR+OIL OUTLET	1/8"
OIL PRESSURE	MIN 20 bar MAX 35 bar
AIR PRESSURE	MIN 3 bar MAX 10 bar
CLAMPING SCREWS	5x60M SCREW
LUBRICANTS	OLIO MAX 220 cSt 40°C
TEMPERATURE	FROM 5°C TO 80°C
MOUNTING POSIT.	UPSIDE OUTLET

ORDER CODES	
SINGLE PARTS	
CODE	DISCHARGE
02.909.0.010	10 MM ³
02.909.0.020	20 MM ³
02.909.0.030	30 MM ³
02.909.0.060	60 MM ³
02.909.0.100	100 MM ³
02.909.0.160	160 MM ³

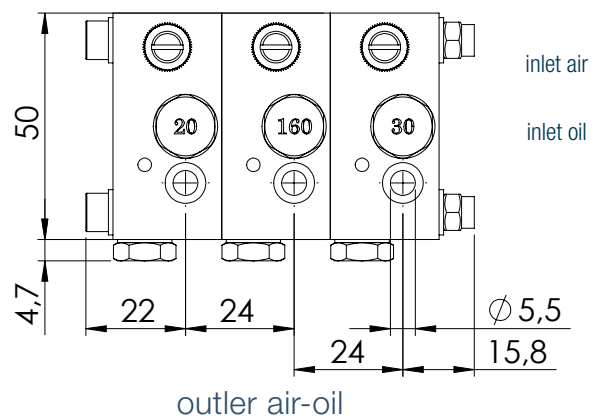
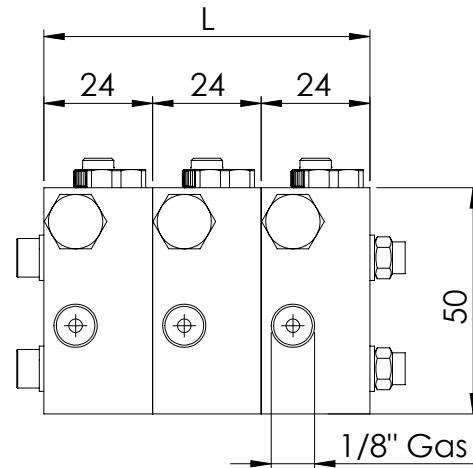
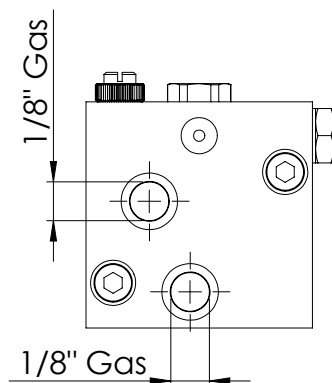
Overall Dimnsions

AIR+OIL MIXING VALVES MIXER-3

Air+oil mixing valves Mixer-3 can be combined until 8 or more blocks. To have groups of higher valves please be so kind as to contact our technical department. Every outlet port has to be connected to the lube point. Discharges can be chosen between 10 mm³, 20 mm³, 30 mm³, 60 mm³, 100 mm³ and 160 mm³.

TIE RODS CODE	N. OF BLOCK
A70.093279	2
A70.093280	3
A70.093281	4
A70.093282	5
A70.093283	6
A70.093284	7
A70.093285	8



Ordering the code you will have just one tie rod. Every block needs two tie rods.

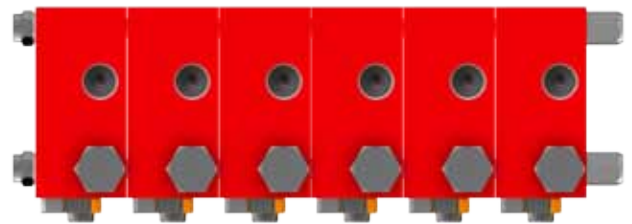

Order Codes

CODE	OUTLETS
MX01	1
MX02	2
MX03	3
MX04	4
MX05	5
MX06	6
MX07	7
MX08	8

DISCHARGE	MARKING
10 mm ³	10
20 mm ³	20
30 mm ³	30
60 mm ³	60
100 mm ³	100
160 mm ³	160

Order example:
MX06:20-160-10-60-100-30



Please indicate valves discharge when ordering, from left to right, as shown in the example below.

to order a Mixer-3 of 6 outlets and indicating discharges

AIR+OIL MIXING VALVES MIXER-3

STANDARD FITTINGS

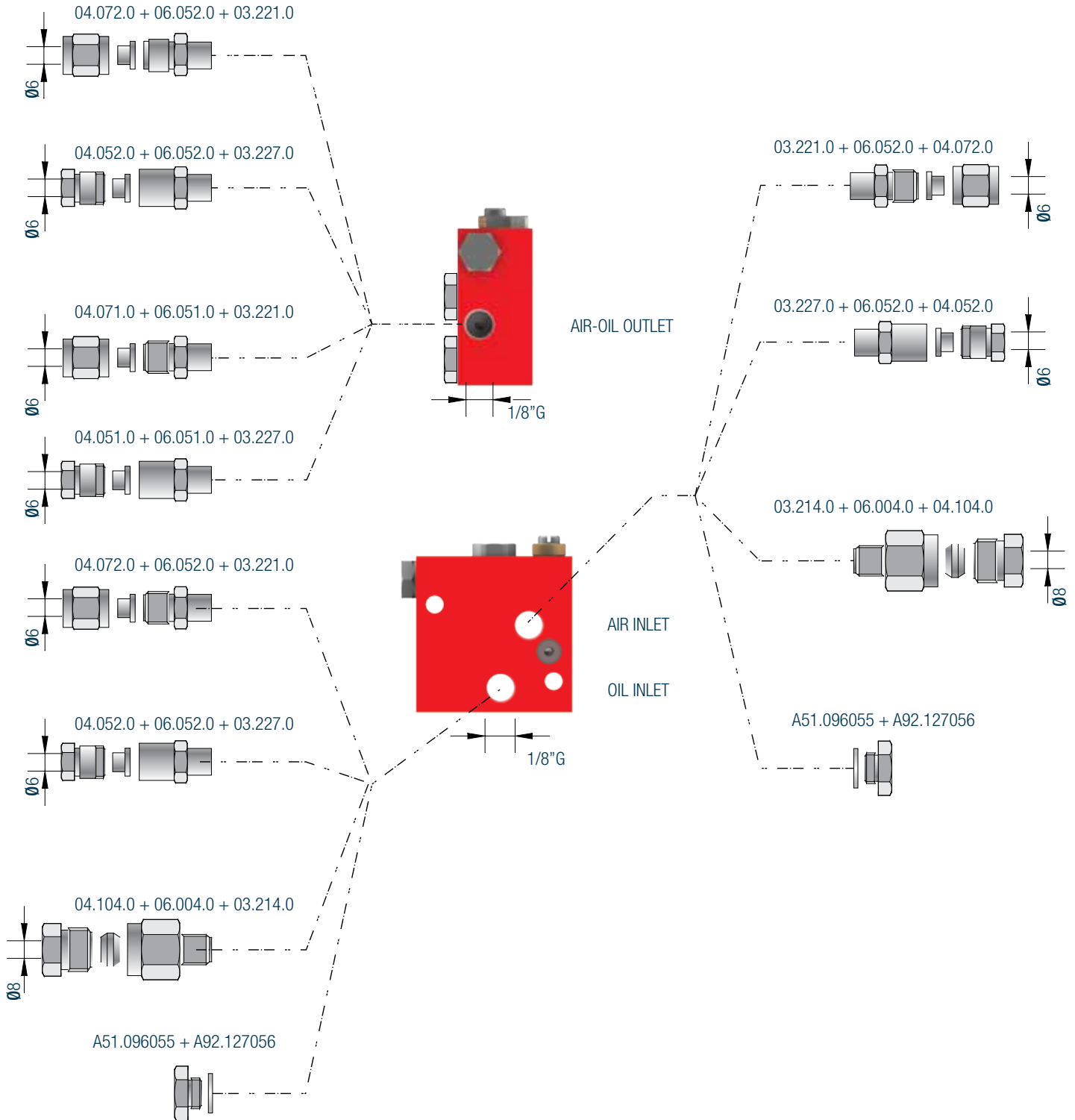

L'aspetto dei prodotti può essere soggetto a modifica senza preavviso

STANDARD FITTINGS

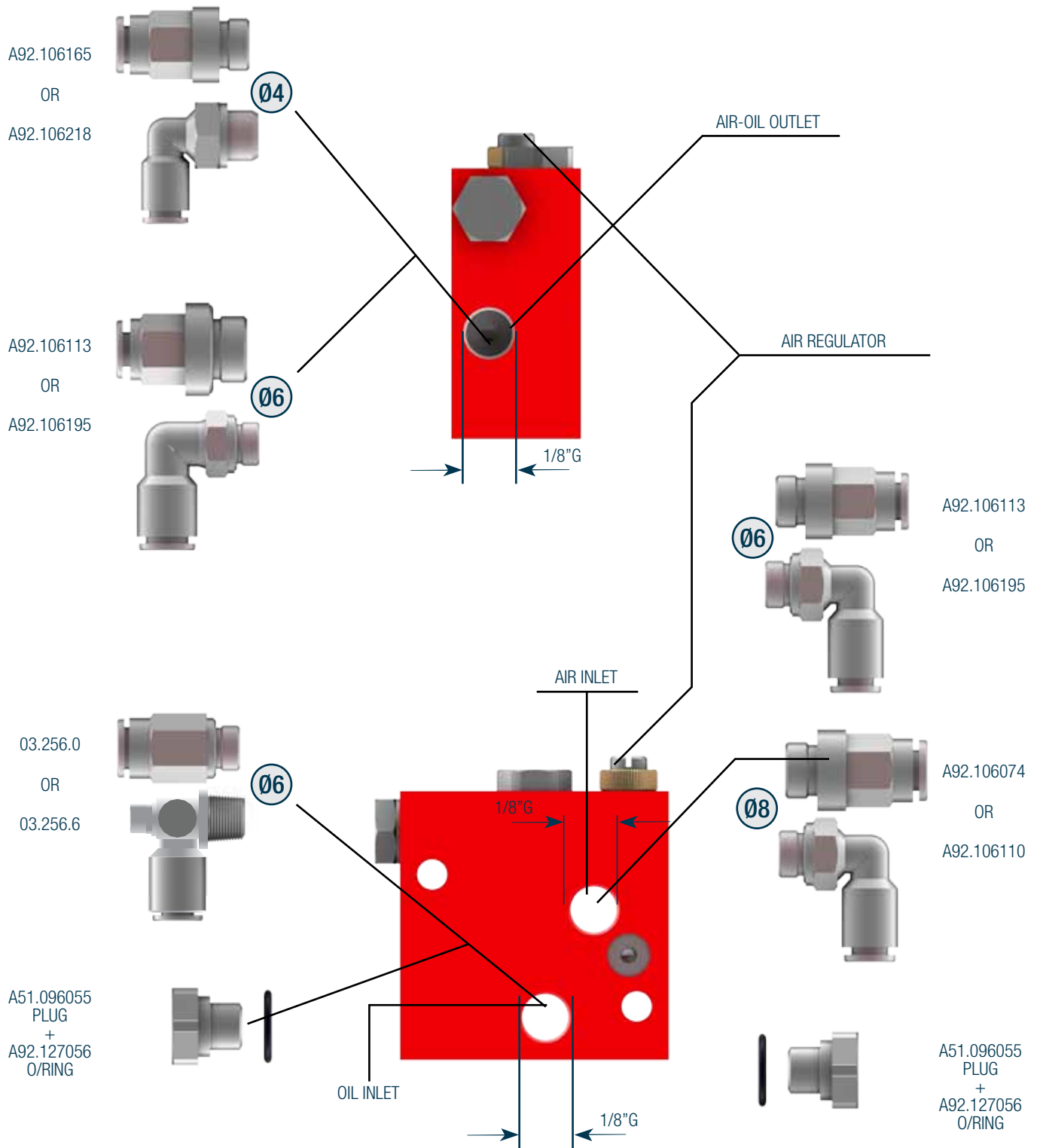

L'aspetto dei prodotti può variare senza preavviso.

PRESSURE SWITCH SP-43

The sp-43 membrane pressure switches are employed to control the minimum or maximum pressure. They are designed with an hexagonal body, a nbr oil proof membrane, silver contacts, body with screwed clamp, connection terminals spring for the pressure to be checked. “no” or “nc” electric contact position refers to the status in absence of pressure. They can be used in circulating oil system and the pressure can be adjusted by a small screwdriver the v screw paying attention not to affect the spring. It is advisable to protect the electric connections and the internal devices against moisture and dust infiltration by means of protection cp-1.

FEATURES

OPERATING VOLTAGE	250 V AC
OPERATING POWER	100 VA
CURRENT INTENSITY	0.5A RESIS. 0.25A INDUT.
OPERATING TEMPERATURE	-5 °C +60 °C
ENCLOSURE	IP 54
MAXIMUM STROKES	200/1'
ISOLATING VOLTAGE	1500 V

CODES FOR ORDER PRESSURE SWITCH

1500 V

CODE	TYPE NO	BAR	CODE	TYPE NC	CODE	TYPE NO	BAR	CODE	TYPE NC		
49.061.0	PMN	2A	49.062.0	PMN	2C	49.063.0	330	330	49.064.0	PMN	2CD
49.061.1	PMN	10A	49.062.1	PMN	10C	49.063.1	355	355	49.064.1	PMN	10CD
49.061.2	PMN	20A	49.062.2	PMN	20C	49.063.2	330	330	49.064.2	PMN	20CD
49.061.3	PMN	50A	49.062.3	PMN	50C	49.063.3	355	355	49.064.3	PMN	50CD
49.061.4	PMN	80A	49.062.4	PMN	80C	49.063.4	330	330	49.064.4	PMN	80CD
49.061.5	PMN	150A	49.062.5	PMN	150C	49.063.5	355	355	49.064.5	PMN	150CD
49.061.6	PMN	250A	49.062.6	PMN	250C	49.063.6	330	330	49.064.6	PMN	250CD

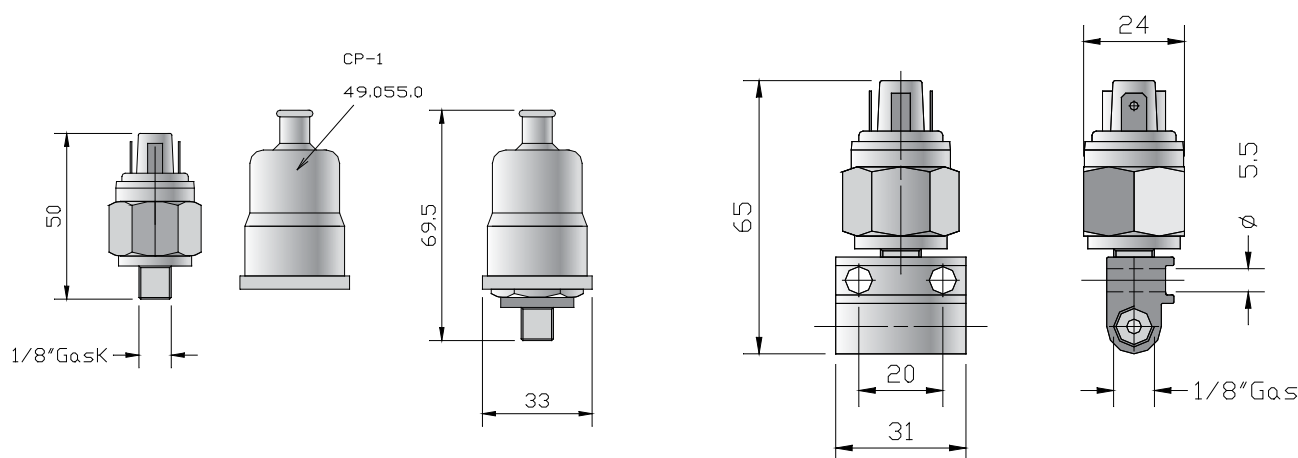

PFL END OF LINE PRESSURE SWITCH



The pfl end of line pressure switches are used to check the set pressure on the main line of a lubrication system with metering valves. They are made with a revolving steel body (it is possible to adjust the pressure switch to connect the main line) where are the spring and the piston, the adjustable ring nut to set the pressure that have to be controlled and the fitting for the main line tube. Inside the alluminium body there is the microswitch. This pressure switch have to be installed at the end of the main line to have a correct control of the pressure.

The pfl pressure switches are very useful to be installed in lubrication systems with metering valves to check if the main line is broken or plugged. The pressure achieved signal have not to be used to stop the pump, but have to be used from the plc or the electronic card only to understand that the system is well working.

These pressure switch are supplied complete of a quadropole connector with enclosure ip-65.

FEATURES	
VOLTAGE	250 V AC
CURRENT	5A
CONTACTS	"NA" – C – "NC"
PROTECTION	IP – 65
CONNECTION	M10x1 TUBE 4 – 6 mm
TEMPERATURE	0 °C + 80 °C
LUBRICANTS	OIL MIN 50 cSt 40°C SOFT GREASE MAX NLGI 00

Codes to order

CODE	ADJUSTABLE RANGE
49.045.0	5 - 15 bar
49.046.0	10 – 65 bar

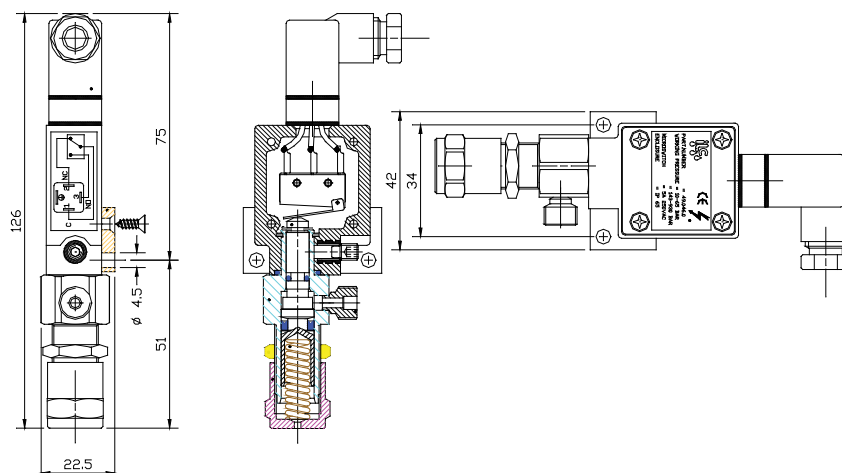

OIL AND GREASE LINE STRAINERS

**WORKING MAXIMUM PRESSURE 500 BAR
OVERALL DIMENSION**

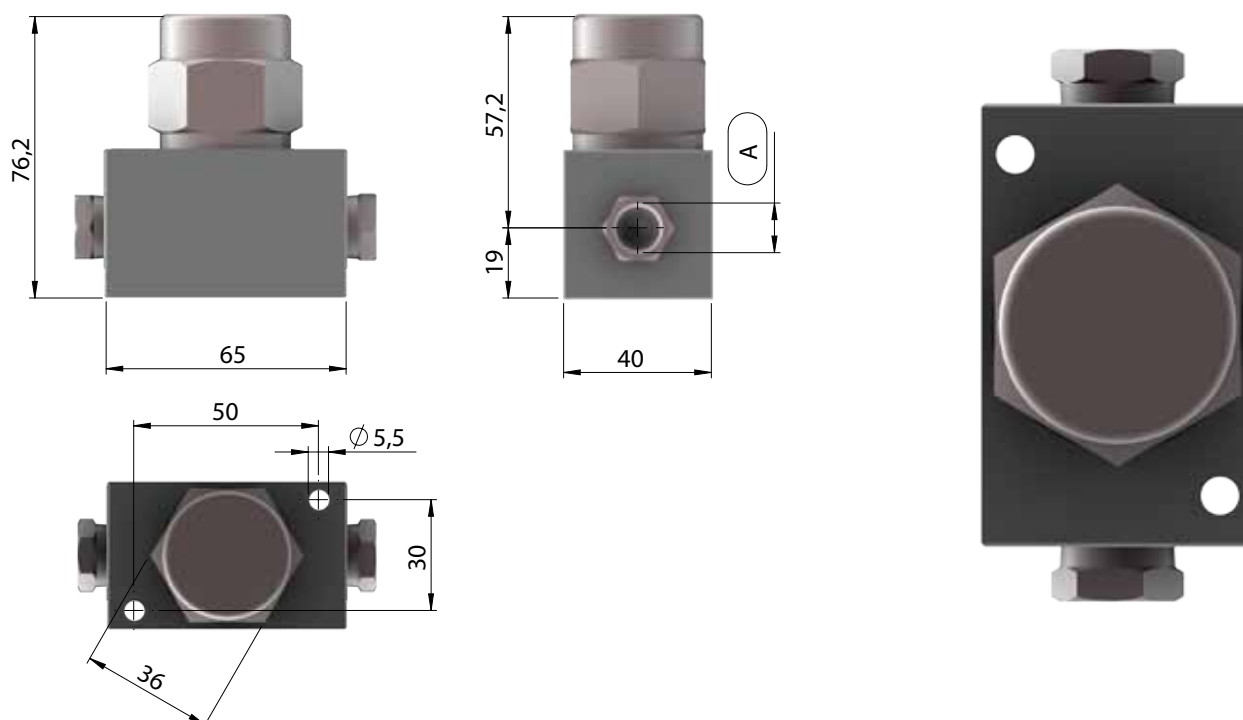

Codes to order oil strainers

CODE	MICRON	THREAD "A"	STRAINER ELEMENT
07.260.0	25	1/4"	07.262.0
07.260.1	40	1/4"	07.262.1
07.260.2	60	1/4"	07.262.2
07.260.3	125	1/4"	07.262.3
07.260.4	25	3/8"	07.262.0
07.260.5	40	3/8"	07.262.1
07.260.6	60	3/8"	07.262.2
07.260.7	125	3/8"	07.262.3

Codes to order grease strainers

CODE	MICRON	THREAD "A"	STRAINER ELEMENT
07.261.0	150	1/4"	07.262.4
07.261.1	300	1/4"	07.262.5
07.261.2	150	3/8"	07.262.4
07.261.3	300	3/8"	07.262.5
07.261.4	150	1/2"	07.262.4
07.261.5	300	1/2"	07.262.5



The cme-card electronic cards are supplied to drive and to control lubrication systems with metering volumetric valves and cyclic type lubricators (pneumatic or electric). By mean of the jumper j2 it is possible to select to drive a system complete with pressure switch (with control) or a syestem only for working and pause time (without control). By mean of the jumper j1 it is possible to have prelube or not. Pressing the push button will end the pause period and start the pump that will run for the working peiod. The push button is also used to clear a system fault indication. The pause and working period can be adjusted by mean of dip-switches.

On these elecronic cards it is possible to connect the low level switch and the pressure switch signals and he has a potential free contact. The cme-card has not a protection box so he has to be installed inside the control board of the machine.

CARATTERISTICHE	
SUPPLY VOLTAGE	24 V DC, 115 V AC 0 230 V AC
PAUSE TIME	FROM 5 MINUTES TO 21 HOURS
WORKING TIME	FROM 5 TO 90 SECONDS
PUSH BUTTON	EXTRA CYCLES – RESET
GREED LAMP	ON LINE
YELLOW LAMP	WORK PUMP
RED LAMP	LOW LEVEL ALARM PRESSURE ALARM
TEMPERATURE	FROM -10 °C TO + 60 °C

Codes for order

CODE	VOLTAGE
A91.111101	24 V DC
A91.111070	115 V AC
A91.111071	230 V AC

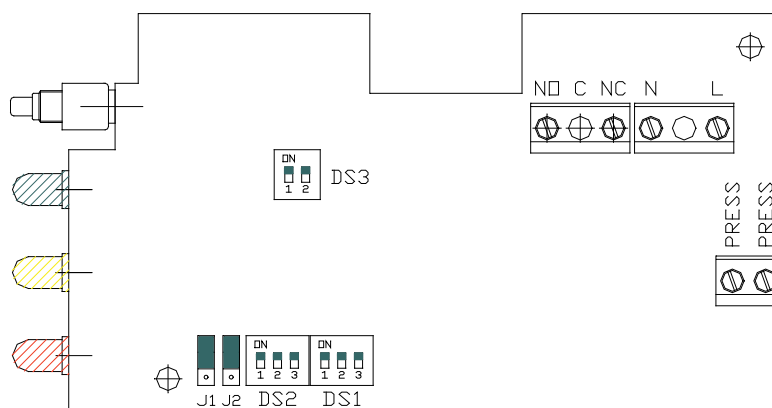

L'aspetto dei prodotti può essere soggetto a modifica senza preavviso

VOLUMETRIC SYSTEM

MEDIUM VISCOSITY RATE cSt 40°C	ISO SYMBOL
10	ISO VG-10
15	ISO VG-15
22	ISO VG-22
32	ISO VG-32
46	ISO VG-46
68	ISO VG-68
100	ISO VG-100
150	ISO VG-150
220	ISO VG-220
320	ISO VG-320
460	ISO VG-460
680	ISO VG-680
1000	ISO VG-1000

GRADE NLGI	PENETRATION INDEX ASTM
000	445 – 475
00	400 – 430
0	355 – 385
1	310 – 340
2	265 – 295
3	220 – 250
4	175 – 205
5	130 – 160
6	85 – 115

NLGI : NATIONAL LUBRICATING GREASE INSTITUTE
ASTM : AMERICAN SOCIETY FOR TESTING AND MATERIALS

VISCOSITY COMPARISON SCHEDULE

cSt 40° C	SUS 100°F	E 50°C	cSt 40° C	SUS 100°F	E 50°C	cSt 40° C	SUS 100°F	E 50°C
2	32.64	1.119	41	190.5	5.465	200	925.6	26.32
3	36.05	1.217	42	195.0	5.590	210	971.8	27.65
4	39.15	1.308	43	199.5	5.720	220	1018	28.95
5	42.36	1.400	44	204.1	5.845	230	1065	30.28
6	45.57	1.481	45	208.7	5.975	240	1111	31.60
7	48.77	1.563	46	213.3	6.105	250	1157	32.90
8	52.07	1.653	47	217.9	6.235	260	1203	34.25
9	55.48	1.746	48	222.5	6.365	270	1249	35.55
10	58.88	1.837	49	227.1	6.495	280	1296	36.85
11	62.39	1.928	50	231.7	6.630	290	1342	38.18
12	66.00	2.020	55	254.8	7.238	300	1388	39.50
13	69.70	2.120	60	277.8	7.896	310	1434	40.80
14	73.50	2.219	65	300.8	8.554	320	1480	42.12
15	77.31	2.323	70	323.8	9.912	330	1527	43.45
16	81.21	2.434	75	347.0	9.870	340	1574	44.75
17	85.22	2.540	80	370.2	10.53	350	1620	46.10
18	89.32	2.664	85	393.3	11.19	360	1666	47.40
19	93.43	2.755	90	416.5	11.85	370	1712	48.70
20	97.64	2.870	95	439.5	12.51	380	1759	50.00
21	101.8	2.984	100	462.6	13.16	390	1805	51.35
22	106.1	3.100	105	485.8	13.82	400	1851	52.65
23	110.4	3.215	110	509.0	14.47	450	2082	59.25
24	114.7	3.335	115	532.1	15.14	500	2314	65.80
25	119.0	3.455	120	555.3	15.80	550	2545	72.40
26	123.4	3.575	125	578.5	16.45	600	2777	79.00
27	127.8	3.695	130	601.6	17.11	650	3008	85.60
28	132.3	3.820	135	624.7	17.76	700	3239	92.20
29	136.7	3.945	140	647.9	18.43	750	3471	98.80
30	141.1	4.070	145	671.1	19.08	800	3702	105.3
31	145.5	4.195	150	694.2	19.75	850	3934	111.9
32	149.9	4.320	155	717.2	20.40	900	4165	118.5
33	154.4	4.445	160	740.4	21.05	950	4396	125.0
34	158.9	4.570	165	763.4	21.72	1000	4628	131.6
35	163.4	4.695	170	786.6	22.38			
36	167.9	4.825	175	809.7	23.03			
37	172.4	4.955	180	832.9	23.70			
38	176.9	5.080	185	856.1	24.35			
39	181.4	5.205	190	879.3	25.00			
40	185.9	5.355	195	902.5	26.67			

cSt = CENTISTOKES 40°C

SUS =

E° =



POMAC
LUB SERVICES BVBA

Kortrijkstraat 187 B-8770 Ingelmunster
Tel. +32 (0)51 316 205 - Fax +32 (0)51 309 621 info@pomac.be - www.pomac.be